

First Canadian Place Retail Tenant Design Criteria

100 King St. West, Toronto, Ontario

Brookfield
Properties



Table of Contents

Introduction

1.1	Welcome to First Canadian Place	5
1.2	Building and Consultant Directory	6
1.3	Approved Contractors	7
1.4	Introduction to the Tenant Design Criteria Manual	8
1.5	Key Plan and Criteria Zones	9
1.6	Glossary of Terms	10

Retail Design Guidelines

2.1	Typical Retail Storefront Design	12
2.2	Landlord Control Zone	13
2.3	Storefront Security Systems	14
2.4	Closure Systems	15
2.5	Storefront Materials and Finishes	16
2.6	Interior Lighting Requirements	17
2.7	Store Interior Design Criteria	18
2.8.1	Primary Signage	19
2.8.2	Secondary Signage	20

Retail Design Details

3.1	Typical Storefront Conditions	22
3.2	Variable Demising Conditions	23
3.2.1	Variable Demising Conditions - Details	24

Marketplace Design Guidelines

4.1	Design Approach and General Requirements	27
4.2	Typical Marketplace Storefront Design	28
4.3	Landlord Control Zone	29
4.3	Materials and Finishes	30
4.3.1	Landlord's Base Building Materials	31

4.4	Counter	32
4.5	Closure Grille	32
4.6	Tenant Menu Board Criteria	33
4.7	Interior Lighting Requirements	34
4.8	Store Interior Design Criteria	35
4.9	Primary Signage	36
4.10	Secondary Signage	37

Marketplace Design Details

5.1	Typical Condition A	39
5.2	Typical Condition B	40
5.3	Typical Sections	41
5.4	Variable Demising Conditions	42

Food Terrace Design Guidelines

6.1	Design Approach	45
6.2	Food Terrace Zones	45
6.3	General Requirements	46
6.4	Food Terrace Eateries Storefronts	46
6.5	Counters	47
6.6	Closure Systems	48
6.7	Demising Walls	48
6.8	Bulkheads and Storefront Signage	49
6.9	Menus and Interior Signs	51
6.10	Ceiling Requirements	52
6.11	Interior Lighting Requirements	52
6.12	Tenant Responsibilities	54
6.13	Brand Experience	54
6.14	Tenant Identity and Food Display	55

Food Terrace Design Details

7.1	Key Plan and Preferred Queue	57
7.2	Storefront Typical Elevation	58
7.3	Storefront Typical Plan	59
7.4	Storefront Typical Section	60
7.5	Storefront Details	61

Mechanical and Electrical Requirements

8.1	Landlord's Work	63
8.2.1	General Requirements	66
8.2.2	Electrical Requirements	67
8.2.3	Mechanical Requirements	68

Tenant Submission Requirements

9.1	Tenant Information Package	70
9.2	Tenant Design Approval Process	71
9.3	Preliminary Submission Requirements (Step 1)	72
9.4	Final Submission Requirements (Step 2)	73
9.5	Final Review and Approval Process (Step 3)	76
9.6	Permit Submissions	76

Construction Documentation

10.1	Commencement of Tenant Construction	78
10.2	Procedures During Construction	79
10.2.1	Tenant's Work	79
10.2.2	Inspection of Tenant Premises	79
10.2.3	Hoarding	80
10.3	Completion of Tenant Construction	80
10.4	Mechanical Requirements	81
10.4.1	Smoke Evacuation System	81
10.4.2	Fire Hose Coverage	81
10.4.3	Sprinklers	82
10.4.4	Chilled Water Supply	82
10.4.5	Ventilation	82
10.4.6	Controls	82
10.4.7	Heating Water Supply	82
10.4.8	Plumbing	83
10.4.9	Additional Requirements for Food Preparation tenants	83
10.5	Electrical Requirements	84
10.5.1	Power Service	84
10.5.2	Lighting	84
10.5.3	Data and Communications	84
10.5.4	Security	84
10.5.5	Additional Requirements for Food Preparation Tenants	84
10.6	General Requirements	85
10.7	Consultant's Checklist	85

Required Forms

11.1	Form Requirements	87
	Tenant and Contractor's Acknowledgement Form	88
	Electrical Load Summary Requirements	89

1. Introduction



1.1 Welcome to First Canadian Place

Located in the heart of Toronto's financial district, First Canadian Place is an inspiring 72- stories, 2.7 million square feet, office, banking and retail complex. The retail component now features 70 world-class stores, services and restaurants.

In today's retail environment, creating dynamic and inviting storefronts is essential to enticing time-pressed shoppers and food seekers. While First Canadian Place encourages originality and ingenuity in design, we also maintain a certain degree of overall design consistency.

This Retail Tenant Design Criteria Manual provides guidelines on ensuring your project meets Brookfield Properties' standards.



1.2 Building Directory

Landlord Contacts

Landlord

FCP (BOPC) Ltd., BOPC FCP LP, BOPC FCP GP Inc., ARI FCP Holdings Inc., ARI FCP Investment LP, ARI FCP GP Inc., CCIPB FCP Holding Inc., CPPIB FCP LP, CPPIC FCP GP Inc., Brookfield Properties (Canada) Inc. and Brookfield Properties (PI) Inc.
c/o Brookfield Properties (PI) Inc.
 Brookfield Place
 181 Bay Street, Suite 700
 Toronto, ON M5J 2T3.

Director, Retail

Lucie Bisson
 Tel: 416-862-9918
 First Canadian Place, 100 King Street West
 Concourse Level, Management Office
 Toronto, ON, M5X 1A9
lucie.bisson@brookfieldproperties.com

Manager, Tenant Services

Lyna Jato
 Tel: 416-862-2952
 First Canadian Place, 100 King Street West
 Concourse Level, Management Office
 Toronto, ON, M5X 1A9
lyna.jato@brookfieldproperties.com

Senior Manager, Building Operations

Fernando Dias
 Tel: 416-862-6076
 First Canadian Place, 100 King Street West
 Concourse Level, Management Office
 Toronto, ON, M5X 1A9
fernando.dias@brookfieldproperties.com

Manager, Building Operations

Jim Ohlman
 Tel: 416-862-6154
 First Canadian Place 100 King Street West
 Level B-3, Toronto, ON M5X 1A9
james.ohlman@brookfieldproperties.com

Construction Services, Project Managers

Address: **Brookfield Properties Canada Management LP**
 Brookfield Place
 181 Bay Street Suite 700
 Toronto, ON M5J 2T3

James Elliott
 Tel: 416-369-4909
james.elliott@brookfieldproperties.com

Rowena DeLasAlas
 Tel: 416-966-7539
rowenajoy.delasalas@brookfieldproperties.com

Building Contacts

Security/Control Centre **Tel: 416-862-6319**

**Elevator/Loading Dock/
Garbage bin booking** **Tel: 416-862-6262**

Housekeeping **Tel: 416-862-6328**

1.2 Consultant Directory

Base Building Contacts

Building Code Consultants LRI Engineering Inc.	LRI Engineering Inc. Tel: 416-515-9331 x 345 170 University Avenue, 3rd Floor - Box 1 Toronto, ON M5H 3B3
Architects	Bregman + Hamann Tel: 416-596-2299 481 University Avenue Toronto, ON, M5G 2H4
Structural Engineers	Entuitive Corporation David Watson Tel: 416-477-5830 200 University Avenue, 7th Floor Toronto, ON M5H 3C6 david.watson@entuitive.com
Mechanical and Electrical Engineers Tenant Renovations	The Aquila Group David Ng Tel: 416-340-1937 40 University Avenue, Toronto, ON M5J 2H7 dng@theaquilagroup.com
Mechanical Engineering Consultants	The Aquila Group David Ng Tel: 416-340-1937 40 University Avenue, Toronto, ON M5J 2H7 dng@theaquilagroup.com
Electrical Engineering Consultants	Mulvey & Banani International Inc. Rob Marcuzzi Tel: 416-751-2520 90 Sheppard Avenue East, Suite 500, Toronto, ON M2N 3A1 rob@mbii.com

1.3 Approved Contractors

Mechanical	MultiTech Trades Corp.	T: 905.812.7900	Fireproofing	Donalco Inc.	T: 416.292.7118
	Commercial Mechanical Systems	T: 416.609.9992		Reno Firestoppers	T: 289.251.3047
	Modern Niagara Mechanical	T: 416.360.1617		Pro Firestop	T: 416.293.0993
	Plan Mechanical	T: 416.635.9040			
	Onyx Mechanical	T: 905.866.6699			
	Opus Mechanical	T: 416.312.4500	Roofing	Simple Gooder	T: 416.743.5370
Electrical	Ampere Ltd.	T: 416.661.3330	Locksmith	Bothwell Accurate	T: 905.673.0615
	Guild Electric Limited	T: 416.288.8222		Reilly Lock	T: 416.256.7222
	Plan Group	T: 416.522.5930			
	Campbell & Kennedy Electric Ltd.	T: 905.761.8550			
	Symtech Innovations	T: 905-940-8044			
Sprinklers	SimplexGrinnell	T: 905.212.4400			
	Modern Niagara Mechanical	T: 416.360.1617			
	Vipond Automatic Sprinklers	T: 905.564.7060			
	Onyx – Fire Protection	T: 416.674.5633			
Controls	Johnson Controls	T: 905.474.5388			
Fire Alarm	Guild Electric Limited	T: 416.288.8222			
	Plan Group	T: 416.575.6371			
	SimplexGrinnell	T: 905.212.4622			
	JD Collins	T: 905.660.4535			
UTILITY SUB-METERING (Hydro, water, gas, BTU)	Carma Industries Inc.	T: 416.260.4264			
Air Balancing	Design Test & Balance	T: 905.886.6513			
	Technical Air Balancing Inc.	T: 416.492.9408			
XRaying & Core	CB Coring Ltd.	T: 905.841.8877			
Drilling	Canadian Cutting & Coring	T: 905.624.1414			
	Graff Concrete Cutting & Coring	T: 905.457.8120			

1.4 Introduction to the Tenant Design Criteria Manual

Our Retail Tenant Design Criteria Manual has been created to ensure that all new store designs or renovations/alterations to existing stores are in keeping with First Canadian Place's established operational and design specifications. All Tenant leasehold improvements, however small or limited in scope must be fully reviewed and approved by our office prior to commencement of construction. This document should also be reviewed in conjunction with the Tenant Design and Construction Manual.

To ensure the design integrity of First Canadian Place, all procedural guidelines for Tenant premises work as specified in the individual lease documents is mandatory. Nevertheless, it must be clearly understood that in the event of any ambiguity of, or omission to the wording in this document, the approval authority to proceed or not to proceed with Tenant work will remain solely with the Landlord.

It will also be the Tenant's responsibility to ensure that a copy of this Manual is provided to your Consultants, General Contractor and Sub-Contractors (hereafter called The Contractor(s)) or any other person employed by them, and that the Tenant, its Consultants, its Contractor(s) or any other person, adhere fully to the direction provided herein. Failure by the Tenant or its Designer(s), Contractor(s), or any other person employed by it, to comply with any of the general or specific guidelines because of a lack of understanding in, or awareness of, the Retail Tenant Design Criteria Manual and the Tenant Design and Construction Manual will not be accepted by the Landlord Representative.

It is essential that the Tenant and/or designer and/or space planner visit the site to inspect and verify all site conditions prior to the commencement of Tenant Design.

The Tenant is responsible for hiring consultants licensed in the Province of Ontario for the production of accurate and complete working drawings for the proposed construction within the Leased Premises. Although the Landlord will supply the Tenant with Lease Outline Drawings (LOD's), neither the Landlord nor their representatives shall be responsible for same and the Tenant must verify the as-built condition prior to commencement of the Tenant design.

The Landlord reserves the right, from time to time, to add to or amend the information and procedures contained herein, which will be in effect upon issuance.

1.5 Key Plan and Criteria Zones

This plan is diagrammatic and is intended only for the purposes of indicating the applicable criteria locations.

The Retail Zone

With over 70 stores and services, First Canadian Place is one of Canada's premier urban shopping centres serving over 92,000 people daily.

Full Service Restaurants

First Canadian Place has four full service restaurants providing a diverse mix of culinary experiences to satisfy everyone's taste.

Marketplace

The Marketplace offers shoppers the bustling atmosphere of an urban style market brimming with fresh produce, baked goods and prepared foods.

Food Terrace

With 14 fast food outlets and seating for 1200 people, First Canadian Place's Food Court is one of the largest convenience food offerings in the downtown core.

Legend

Retail Zone	
Marketplace	
Food Terrace	



Street Level

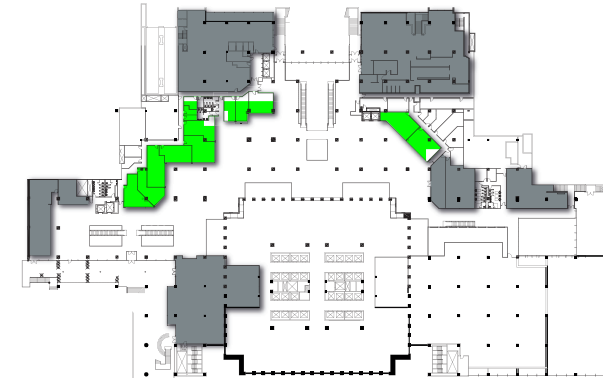

Mezzanine / Food Terrace

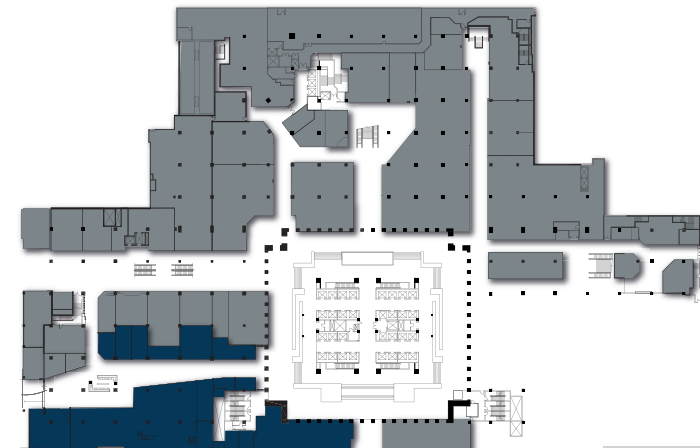

Concourse

1.6 Glossary of Terms

The following are definitions for terms referred to in this criteria:

Tenant Lease Line: The line between the Tenant's leased premises and the mall common area. Tenant Work must be limited to the Tenant side of the Lease Line.

Closure Line: Is defined by the location of the Tenant's closure system, on or behind the Tenant Lease Line. Base building design element (i.e. column, wall, floor) finishes must be continued, by the Tenant, from the Tenant Lease Line to the Closure line. Tenant's finishes can not extend outside the Closure Line into the mall area.

Landlord Control Zone: In order for the Landlord to control the quality and diversity of storefront installations within the mall, it is imperative for certain standards to be maintained. The Landlord's Control Zone is an area across the entire width of the Tenant's storefront, extending from the Tenant's Lease Line into the space as indicated for each storefront type. The Landlord reserves the right to approve, reject or request modifications to the Tenant's design, quality of detailing, finishes and materials, lighting, signage, security system and closure system within this area in order to maintain the standard of design and quality of finishes throughout First Canadian Place.

Signage Zone: An area on the storefront in which the Tenant's signage must be installed.

Demising Cap and Columns: A standard base building marble/stainless steel column or demising cap, found at the end of demising walls separating tenants.

Retail Zone: Is defined by the entire retail area that is visibly open to the public from the Mall space. The Retail Zone extends from the Tenant Lease Line to the Tenant's back wall, including the complete merchandising area. The Landlord reserves the right to approve, reject or request modifications to the Tenant's design, quality of detailing, finishes, materials and lighting within this entire area.

Base Building Channel: A standard vertical architectural metal detail at the center of the demising wall extending from the floor at the Tenant Lease Line to the top of the storefronts. Typically, such mullions occur only when the storefront facade is less than 20'-0" long.

2. Retail Design Guidelines



2.1 Typical Retail Storefront Design

One of a kind storefront designs will be required. The following criteria are to be considered and incorporated into the store designs:

- Tenant storefront construction shall not project beyond the Tenant's lease line, including moldings, or any other architectural elements.
- Signage elements are permitted to exceed the lease line up to 4" into the mall space.
- Tenants shall maximize the use of glass to maintain a show window type concept. The storefront shall be a maximum of 90% transparent. The storefront transparency has to be fenestrated or treated with appropriate architectural materials. Frameless glass storefronts are encouraged. Patch fittings, butt joint glass detailing and minimal hardware are suggested.
- Store openings shall not exceed 40% of the entire storefront width.
- The retail tenant's spaces will be divided with a demising cap. Tenants may have a combination of any two demising elements. The type of dividing cap will be determined by the tenant coordinator. For all special demising cap conditions, i.e. corner location or others, Tenant must coordinate with Landlord.
- The Landlord's floor finish will extend up to the tenant's lease line. The tenant shall provide the floor finish within their lease space.

Not permitted:

- Tenant shall not attach to landlord's stone / stainless steel cladding by means of mechanical fasteners.
- Standard extruded aluminum metal window framing will not be allowed. Channel metal glazing bases must not exceed 100 mm (4") high. Brushed stainless steel or chrome framing are the only accepted materials.



2.2 Landlord Control Zone

The Landlord Control Zone is the first 5'-0" from the lease line into the sales area. As the appearance and design of the Landlord Control Zone is critical to the overall store appearance, all Tenants must comply with the following criteria:

- High quality hard surface flooring such as natural wood, stone or porcelain tile must be used throughout this zone.
- Ceiling materials shall be gypsum board, wood or other type of quality architectural material.
- Recessed HID, halogen, or LED lighting shall be used. Environmentally-friendly lighting solutions are strongly encouraged.
- Sprinkler heads in the ceiling shall be fully concealed with cover plates.
- Show windows which will support dynamic store window displays are encouraged.
- High quality noble materials and finishes shall be used.
- Mobile display fixtures or merchandise, either temporary or permanent, must be placed behind the Tenant entry door closure line. Merchandise racks and display fixtures must not block customer traffic flow in and out of the store.
- Television monitors installed within the Landlord Control Zone can be incorporated into the overall design, but cannot be visible from the common mall area, and must be approved by the Landlord.

Not permitted:

- Freestanding temporary signage or poster holders are not allowed outside of the Tenant closure line and cannot impede traffic flow in and out of the store.
- Acoustical tile ceilings and open ceilings will not be permitted.
- Carpeting and vinyl tile will not be permitted.
- Exposed fluorescent tube light fixtures will not be allowed.
- Monitors, if allowed, and speakers shall not transmit any sound or image into the Landlord's common mall area.

2.3 Storefront Security Systems

- Storefront electronic security systems and any other shoplifting detection devices must be integrated into the Tenant's storefront design. Any such devices must be concealed from view.
- Any theft detection/security device system must be submitted with the overall design submission. No system shall be installed unless approved by the Landlord. Failure to comply with this approval process will result in the removal of such systems by the Landlord at the Tenant's expense.
- All wiring to the security systems must be concealed from view. Power poles and wiring channels exposed to view are not permitted.
- After hours security systems should be monitored off site by tenant. No audible alarms are permitted after hours.



2.4 Closure Systems

- Tenants must provide glass closure systems, which may include pivoting doors, sliding doors, bi-folding glass doors, etc. Frameless glazing is required, although exceptions may be allowed subject to Landlord's approval. Sliding glass doors may be concealed within a pocket. All door tracks, top and bottom must be recessed flush into their surrounding surfaces.
- Swinging glass doors may be left apparent in an open and locked position as long as they do not exceed the lease line.
- Sliding storefronts must be clear glazed and be of a single track variety to minimize interruption of floor finishes. A second sliding glass panel may slide behind the first fixed panel, creating a show window.
- Storefronts can have a maximum entrance opening of 40% of the entire façade.

Not permitted:

- Fully open storefronts are not permitted.
- Solid doors, roll-down or sliding grill type closures and garage doors will not be permitted.
- No multiple stacked glass panels are to be exposed.



2.5 Storefront Materials and Finishes

The Tenant storefront materials are critical in creating a quality and dynamic retail experience. To remain consistent with the noble materials used in the Centre, and to maintain a high standard of design and retail animation, Tenants are encouraged to use natural and durable materials of superior quality.

All materials are to be installed over a durable substrate, and must be long lasting with minimal maintenance requirements. All storefronts shall comply with all governing and applicable building and fire code requirements.

The Landlord reserves the right to reject or request substitutions or adjustments to the proposed finishes. All materials must be approved by the Landlord prior to installation. Nothing is to be attached to the Landlord's finishes.

The retail bulkhead paint colour must match the existing Landlord's bulkhead paint colour: Benjamin Moore – F53501 – ULTRA SPEC WHITE

Acceptable facade materials:

- Tempered glass
- Sandblasted, stained, or etched glass
- Honed, polished or bush hammered natural stone
- Quality porcelain
- Mosaic tiles
- Stainless steel and chrome
- Polished, brushed or textured metals
- Finish-grade figured hardwood, stained and/or lacquered
- Quality acrylic surfaces, polyester resin

Unacceptable facade materials:

- Painted drywall, wallpaper
- Slatwall or pegboard
- Painted metals
- Plastic laminates
- Simulated plastic laminates: brick, stone, wood, etc.
- Vinyl or fabric wallcovering
- Mirrored finishes
- Distressed wood, masonite, plywood paneling, knotty pine, painted wood
- Metal laminates
- Applied vinyl letters

2.6 Interior Lighting Requirements

- Tenants must have dramatic and well illuminated storefronts, emphasizing their visual presentation, display windows and architectural features. Refer to Landlord Control Zone criteria for further details.
- Tenants must have a well illuminated sales area. Appointed accent lighting and varied lighting levels that will create drama and interest is encouraged. Light levels of 25 - 45 foot candle (F.C.) for general merchandise and 125 - 225 F.C. for feature displays are required.
- All light fixtures shall be of high quality commercial grade.
- All light fixtures and installations must conform to all applicable building and construction codes and regulations.
- Tenants are required to use low energy consumption luminaries.
- Recessed or decorative pendant luminaries are acceptable. Decorative pendant lights can be introduced as architectural feature lighting.
- Lighting in coves is to be stagger-mounted for continuous illumination and to prevent hot or dark spots.
- Fluorescent lighting will be allowed as recessed accent lighting for cabinets and counters and is not to be visible by the customers.
- LED or other environmentally-friendly lighting solutions are strongly encouraged.

Not permitted:

- No lighting shall be installed in the Landlord's storefront bulkhead or outside the demised premises other than those installed by the Landlord.
- Suspended or surface mounted track lighting systems will not be permitted.
- Exposed fluorescent or standard fluorescent light fixtures of any kind will not be permitted in the sales area and may only be used in non-public, backstore areas.
- No lamps or bulbs will be permitted that are directed or aimed into the mall.
- No mercury vapour or high pressure sodium lamps, strobe, spinner, chase, or moving type lighting will be permitted.
- Exposed or unshielded neon tube lighting

2.7 Store Interior Design Criteria

- All Tenants are required to provide a high quality, finely detailed and unique interior environment. Interior finishes for flooring, walls, ceiling, lighting, furnishings and décor are to be long-lasting and of superior commercial quality.
- All trade fixtures shall be new and of durable quality and finish consistent with anticipated heavy duty public use.
- All transitions between floor finishes of unequal thickness are to be accomplished by a gradual transition with floor leveling compound to create a smooth and level walking surface.
- Carpeting, if used within the sales area, shall be of the highest quality (minimum 32 oz quality).
- All ceiling construction, including drywall bulkheads and ceilings, are to be properly supported and braced to the building structure.
- The Tenant must submit full details indicating finish treatment at expansion joints where they occur within the retail space.
- Tenant must provide access panels where required to service Landlord and Tenant's electrical and mechanical servicing. Coordinate with base building mechanical and electrical personnel.

Not permitted:

- Standard acoustical tile ceilings will not be permitted within the sales area.
- Vinyl tile or any other sheet flooring goods, as well as simulated materials such as simulated wood planks.
- Tripping hazards such as carpet trim strips and noticeable reducer trims.

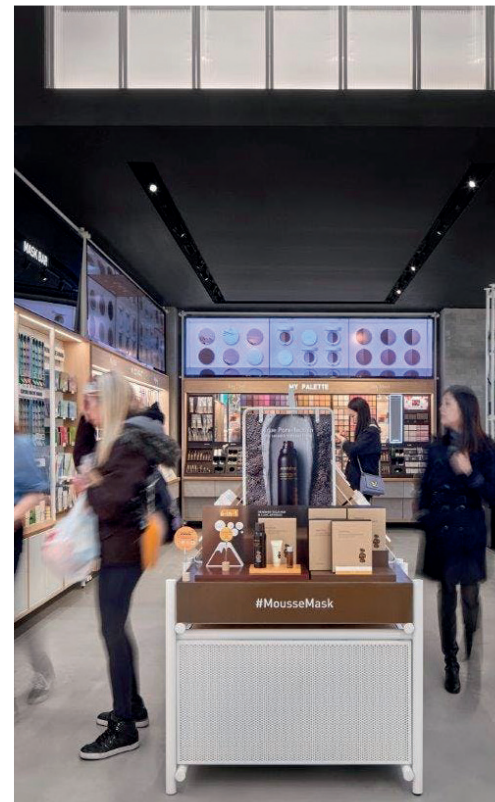

2.8.1 Primary Signage

In order to promote retail individuality along the shopping promenade, tenants are encouraged to provide interesting and unique storefront signs on their facades. All tenants must have one primary storefront sign for the purpose of store identification only.

This sign must be limited to the trade name (as agreed to in the lease documentation with the Landlord) and logo; advertising or product names can not be displayed as part of the signage. Illuminated or non-illuminated graphic panels or boxes, if located within the Landlord Control Zone, may be permitted, subject to Landlord approval.

- Signs must be located within the designated Signage Zone, and must not exceed 40% of the total storefront length and within the Signage Zone. Lettering and icon heights within the Signage Zone are subject to Landlord's approval.
- All conduits, transformers or other related equipment must be completely concealed from view from the mall. Exposed brackets or fastenings must be painted out to minimize their appearance. Manufacturers' or government labels must be concealed from view.
- Signage may be silhouette (halo type) reverse channel letters, illuminated front face letters, three-side illuminated channel letters.
- Internally illuminated cabinet sign with routed out copy and push through acrylic letters are permitted. The sign cabinet must be recessed, or fully integrated into the façade design.
- LED or other environmentally-friendly lighting solutions are strongly encouraged.

Not permitted:

- Signs must not be attached to or suspended from the ceiling.
- No flashing, blinking, animated or audible signs will be permitted.
- Visible or exposed light sources will not be permitted.
- Neon lighting

2.8.2 Secondary Signage

Tenants may be permitted to have a secondary signage at the storefront, subject to Landlord's approval.

Acceptable types of secondary signage may be:

- Sandblasted, etched or vinyl letters / logo on the storefront glass, cut-out metal or wood letters inside the storefront display windows. Vinyl letters /logo are to be mounted on the interior side of the tenants space only.
- Mosaic tile inserts within the tenants floor finish and behind the closure line.
- Secondary signage must be subtle, and should not compete with the primary signage. It cannot cover more than 0.14 sq.m (1.5 sq.ft.) in total area for the storefront.

Not permitted:

- While the signs below may be acceptable in another environment, they would not be acceptable at First Canadian Place for the reasons indicated.
- Exposed or surface mounted box signs.
- Exposed neon tube or open face channel letters with exposed neon tube.
- Paper, cardboard, cloth, foam or other signs that are not professional in appearance.

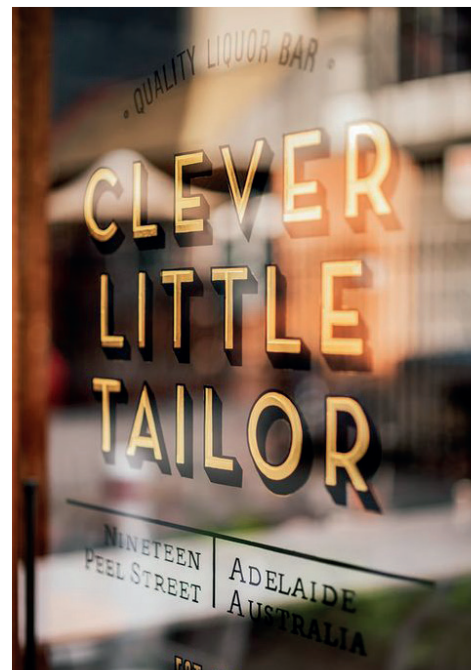

3. Retail Design Details



3.1 Typical Storefront Conditions

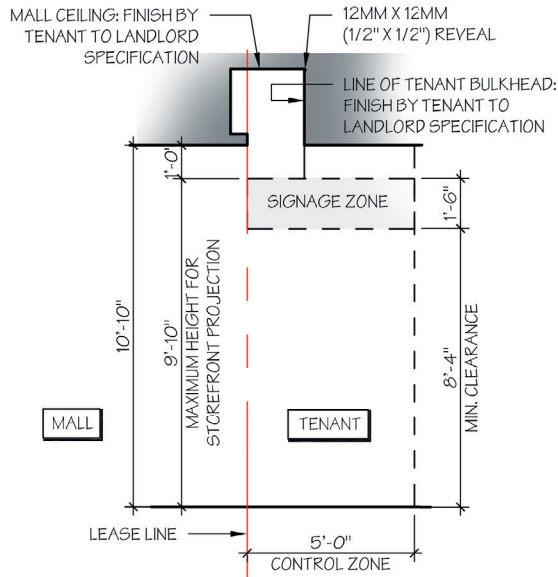

SECTION - TYPICAL STOREFRONT

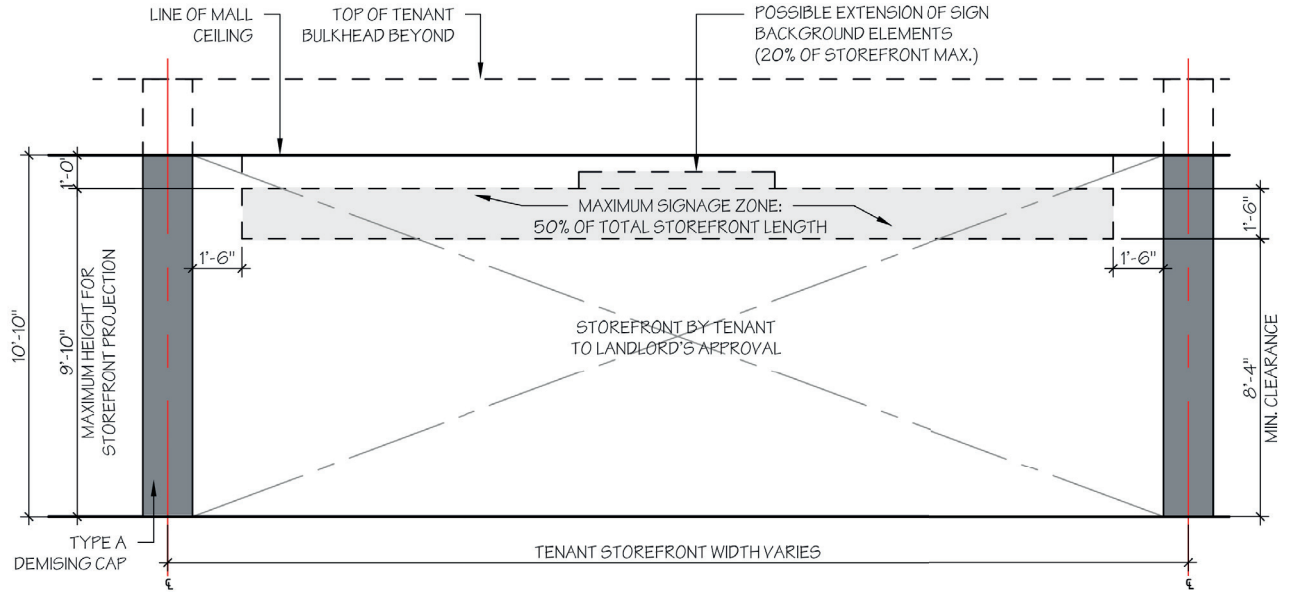

ELEVATION - TYPICAL STOREFRONT

Note: Plans for design intent only. Refer to Architect's LOD drawings for more accurate architectural conditions.

- Legend
- by Landlord
 - by Tenant as per Landlord specifications
 - by Tenant
 - Lease Line

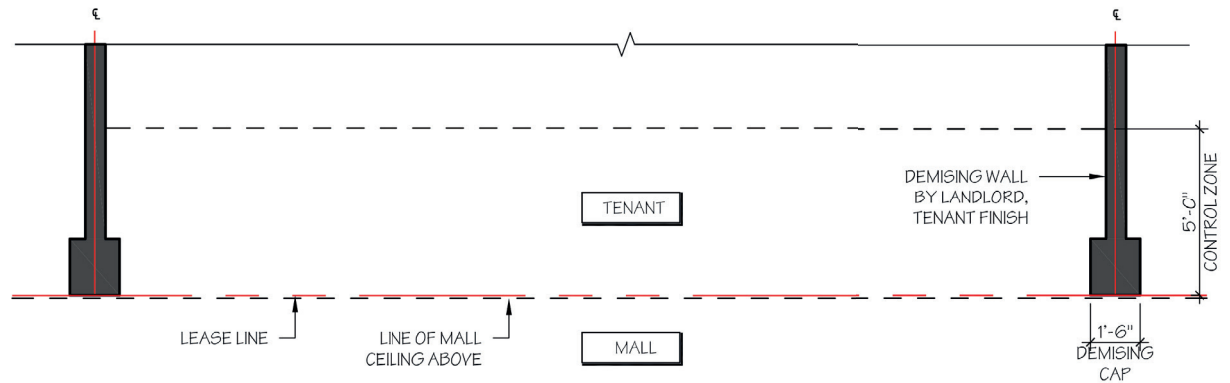

PLAN - TYPICAL STOREFRONT

3.2 Variable Demising Conditions

The retail Tenant's spaces will be divided according to either of the following Landlord's architectural features. Tenants may have a combination of any two demising elements. The type of dividing cap or channel will be determined by the tenant coordinator.

- Type A: Marble demising caps: These are marble clad caps on demising walls for storefront bays of at least 20' wide.
- Type A1: Interim demising cap: This cap, in laquered MDF, is designed for use when a renovated tenant is adjoining a non-renovated tenant. This will be replaced with a standard Type A cap when both tenants are renovated.
- Type B: "U" channels in anodized aluminum: These channels are used when a storefront is less than 20' in width.
- Type C: Marble architectural demising columns: These are full height marble clad structural columns original to the building, which divide the bays.

3.2.1 Variable Demising Conditions - Details

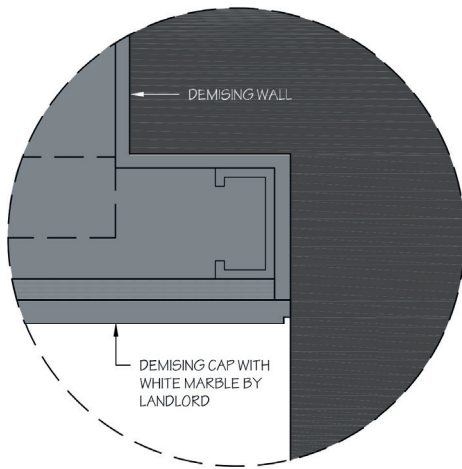

DETAIL 1 - TYPICAL DEMISING CAP

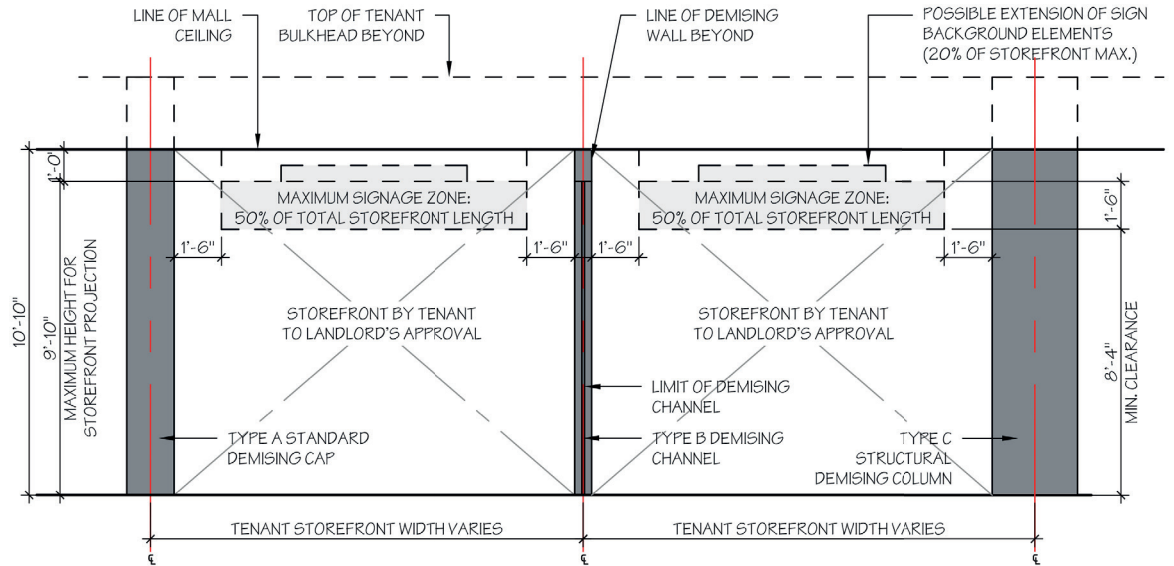

ELEVATION - VARIABLE DEMISING CONDITIONS

Note: Plans for design intent only. Refer to Architect's LOD drawings for more accurate architectural conditions.

- Legend
- by Landlord
 - by Tenant as per Landlord specifications
 - by Tenant
 - Lease Line

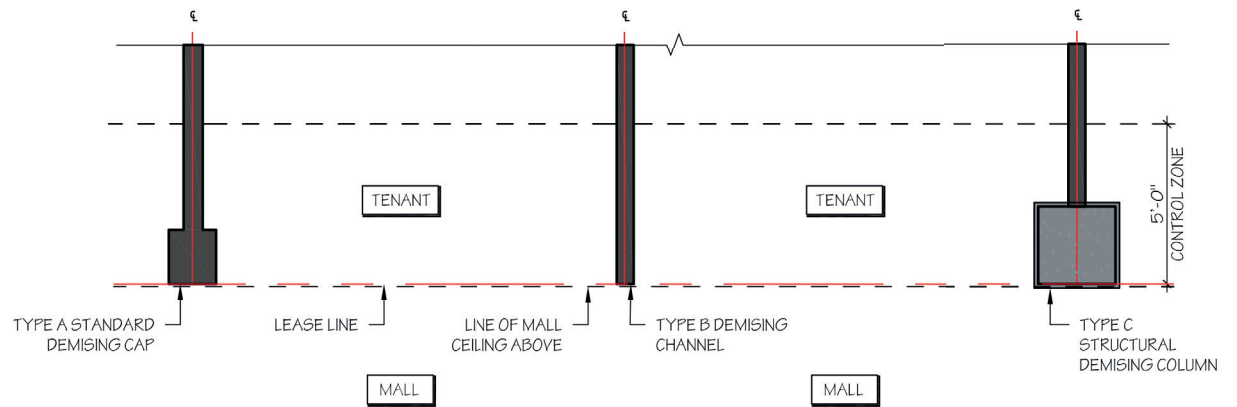

PLAN - VARIABLE DEMISING CONDITIONS

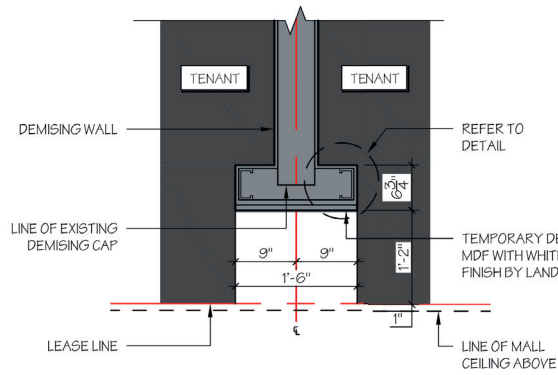

TYPE A - TYPICAL DEMISING CAP (BY LANDLORD)

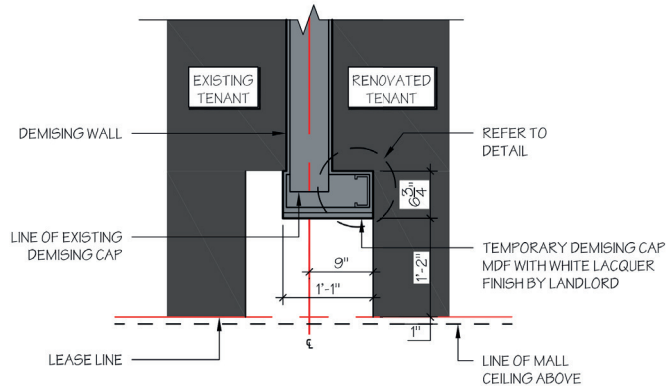

TYPE A1 - INTERIM DEMISING CAP (BY LANDLORD)

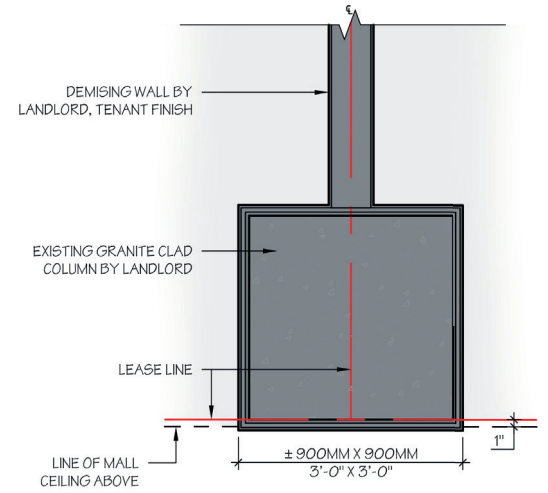

TYPE C - DEMISING COLUMN

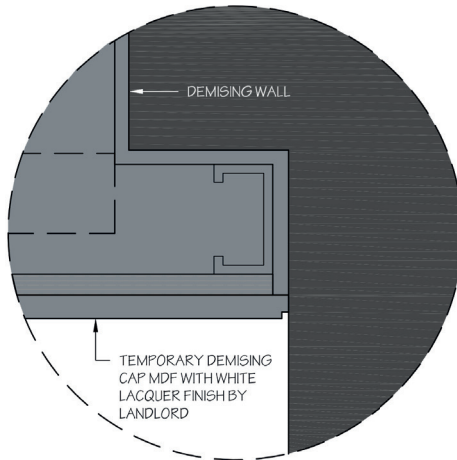

DETAIL 2 - DEMISING CHANNEL

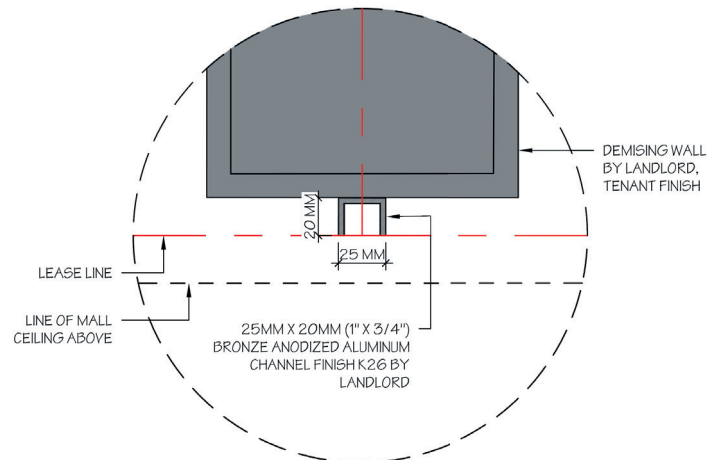

DETAIL 3 - DEMISING CHANNEL

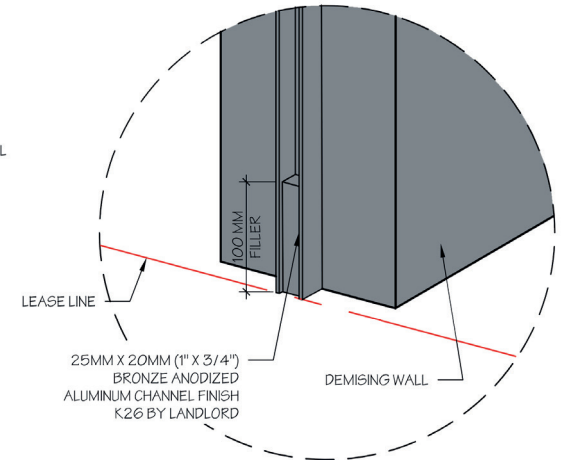

ISOMETRIC - DEMISING CHANNEL

Legend

- by Landlord
- by Tenant as per Landlord specifications
- by Tenant
- Lease Line

Note: Plans for design intent only. Refer to Architect's LOD drawings for more accurate architectural conditions.

4. Marketplace Design Guidelines



4.1 Design Approach and General Requirements

There are two different storefront design conditions at the Marketplace which are differentiated by distinct demising conditions.

The Design Criteria has been planned to allow each Tenant maximum design freedom and to encourage quality store presentations. The base building elements have been consciously designed so as to provide a pleasant environment for the Tenants.

Final preparation areas only are to be exposed to the mall providing the market with a unique combination of animation created by the busy employees preparing fine foods.

Certain construction conditions will occur in some premises while not in others, such as ductshafts with fire-rated enclosures, base building services passing through the premises, etc. Please note that any relocation of base building services will be performed by the Landlord at Tenant's expense. Tenants are obligated to review their leased premises on site in detail to determine what localized conditions may pertain and, to determine in conjunction with the Project Manager how they may treat or otherwise deal with such conditions.

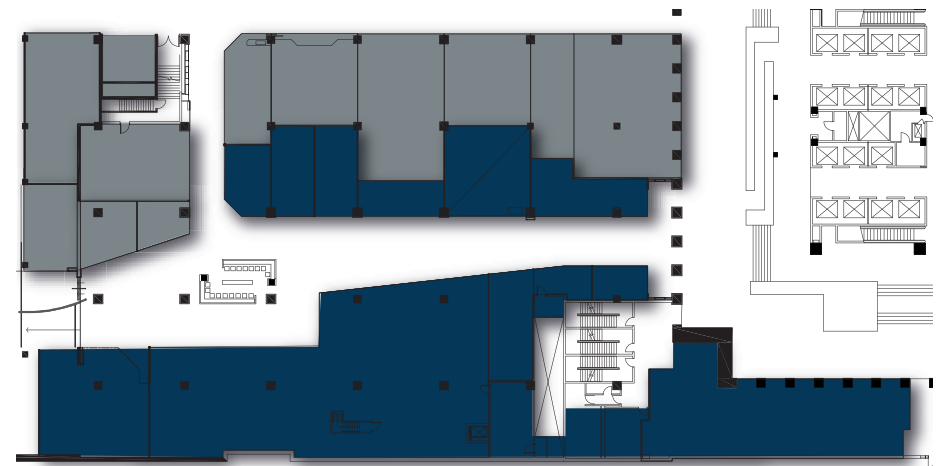

Legend

Retail Zone

Marketplace

4.2 Typical Marketplace Storefront Design

The following criteria are to be considered and incorporated into the store designs:

- All Tenants will be provided with a new closure grille by Landlord at the Tenant's expense.
- Tenant storefront construction shall not project beyond the Tenant's lease line, except for Tenant signage positioned on the signage bulkhead provided by the Landlord.
- Special Condition storefront(s) shall be a minimum of 75% transparent. The opaque areas shall be articulated or treated with appropriate architectural materials.
- Unique storefront designs will be required of all Tenants and subject to review by the Landlord. All fastening must occur behind Landlord's finishes.
- On Special Condition (type A), storefronts are to be frameless butt joint glass detailing, patch hinges and minimal hardware are suggested.
- On Special Condition (type A), closure systems to be frameless glass or Landlord closure system at Tenant's expense.
- Setback for counters for Special Condition (type A) is a minimum of 2'-0" from the lease line.
- In a typical unit (type B), open storefronts are encouraged to promote maximum store penetration except where counter operations occur.
- Setback for typical unit (type B) counters is a minimum of 1'-0" from the Lease Line.

Not permitted:

- Tenant shall not attach to landlord's stone / stainless steel cladding by means of mechanical fasteners.
- Standard extruded aluminum metal window framing will not be allowed. Channel metal glazing bases must not exceed 100 mm (4") high. Brushed stainless steel or chrome framing are the only accepted materials.
- Standard extruded aluminum window framing will not be allowed. Metal or stone bases must not exceed 150 mm (6") high.

4.3 Landlord Control Zone

At the Marketplace, the Landlord's Control Zone extends 3'-0" into the Tenant's space from the Lease Line and across the entire width of the store. The Landlord reserves the right to refuse or request amendments, or modifications to the design of this zone in order to maintain diversity, as well as to maintain the standard of design and quality of finishes throughout First Canadian Place. As the quality of design and the materials used in this zone are critical to the overall appearance of the Marketplace, all Tenants must comply with the following criteria:

- Show windows which will support dynamic store displays are encouraged where applicable.
- Mobile display fixtures or merchandisers, either temporary or permanent, must be and remain placed behind the Tenant entry door closure line with no exceptions.
- The Landlord's floor finish will extend up to 24" into the Design Control Zone area as shown in the storefront typical details. The tenant shall provide the floor finish within their lease space. A metal tile edge trim at the transition finishes is provided by Landlord.
- Finishes on walls and columns in the control zone shall be architectural high quality materials such as wood, porcelain wall tile, porcelain mosaic, glass tile, etc. A single finish from floor to ceiling will be accepted in the Control Zone. Tenant is to provide a 6" stainless steel base.
- A secondary signage will be accepted on side walls.
- Television monitors are allowed in the Landlord Control Zone if they do not transmit sound into the common mall area. Speakers, if allowed, shall not transmit any sound into the Landlord's common mall area.

- Tenant flooring, ceiling and light fixtures in the Control Zone are provided by Landlord.

Bulkhead / Ceiling paint: Benjamin Moore – F53501 – ULTRA SPEC WHITE

Light fixtures: Type A: Philips eW Downlight SM Powercore, 9 LED, 15W, 2700°K, 30° beam (7" square aperature surface mounted white finish).

Flooring: Porcelain tile, Graniti Fiandre, Palisandro Honed, 24" x 24", grout (sanded) Flextile, Pearl 683.

Not permitted:

- Tenant shall not attach their own finishes to the landlord's base building finishes.
- Merchandise racks and display fixtures must not block customer traffic flow in and out of the store for both aesthetic and fire safety reasons.
- Freestanding temporary signage or poster holders are not allowed outside of the Tenant closure line and cannot impede traffic flow in and out of the store. All temporary signage shall be approved by the Landlord prior to installation.

4.3 Materials and Finishes

The Tenant storefront materials are critical in creating a quality and dynamic retail experience. To remain consistent with the natural materials used in the Marketplace, and to maintain a high standard of design and retail animation, Tenants are encouraged to use natural and durable materials of superior quality.

All materials are to be installed over a durable substrate, and must be long lasting with minimal maintenance requirements. All storefronts shall comply with all governing and applicable building and fire code requirements.

The Landlord Control Zone is the entire tenant servery area. The Landlord reserves the right to reject or request substitutions or adjustments to the proposed finishes on the storefront and in the Control Zone. The Landlord prior to installation by the tenant's contractor must approve all tenant storefront materials. Nothing is to be attached to the Landlord's finishes whatsoever.

The quality and upscale character of the First Canadian Place Marketplace is a conscious design statement that the Landlord has gone to great lengths to achieve. It will be of utmost importance that the same theme is carried through into the Tenant spaces as much as possible.

All materials are to be non-combustible and/or treated with a fire retardant chemical where required by jurisdictional authorities.

Materials permitted:

- Tempered glass
- Sandblasted, stained, or etched glass
- Honed, polished or bush hammered natural stone

- Quality porcelain tiles or cladding systems
- Mosaic and glass tiles
- Stainless steel and chrome
- Polished, brushed or textured metals
- Finish-grade figured hardwood, stained and/or lacquered
- Quality acrylic surfaces, specialty surfaces and polyester resin

Materials not permitted:

- Painted drywall or wallpaper of any kind
- Slat wall or pegboard
- Painted metals other than factory finished systems
- Plastic laminates of any kind
- Artificial versions of brick, wood or stone
- Vinyl or fabric wall covering of any kind.
- Mirrored finishes
- Distressed wood, masonite, paneling, knotty pine, painted wood
- Metal laminates
- Applied vinyl letters
- Pegboard
- Fiberglass
- Resilient flooring

4.3.1 Landlord's Base Building Materials

The base building materials outside of Tenant areas are as follows:

- Floor finish:

T-1: Porcelain Tile, Apavisa, Lifestone collection colour Musgo (Geo) Lappato, 12" x 24", grout Flextile, Natural Grey 650

T-2: Porcelain Tile, Apavisa, Lifestone collection colour Musgo (Ville) Natural, 24" x 24", grout Flextile, Natural Grey 650

- Ceiling: Combination of custom suspended walnut wood blades, strip lighting and painted drywall;
- Columns: Marble tile Escarpment, light honed (Ciot), grout Flextile Bone 512 with stainless steel base;
- Demising Caps: Stainless steel.



4.4 Counter

- Design of counter is by Tenant subject to Landlord's approval.
- Counters and equipment at front line must not exceed a height of 4'-6" within the storefront and are to be set back from the Lease Line.
- All elements and merchandising must not extend beyond the closure line.
- It is strongly encouraged to illuminate the food display at front counter. The use of LED or incandescent lighting is strongly encouraged in order to accentuate the food product in the most appetizing fashion. Fluorescent lights will not be permitted in the Tenant's front area open to public view.
- Where required, Tenant must provide access panels to facilitate electrical and mechanical access. All tray slides must be equipped with concealed lighting illuminating the Tenant's counter.

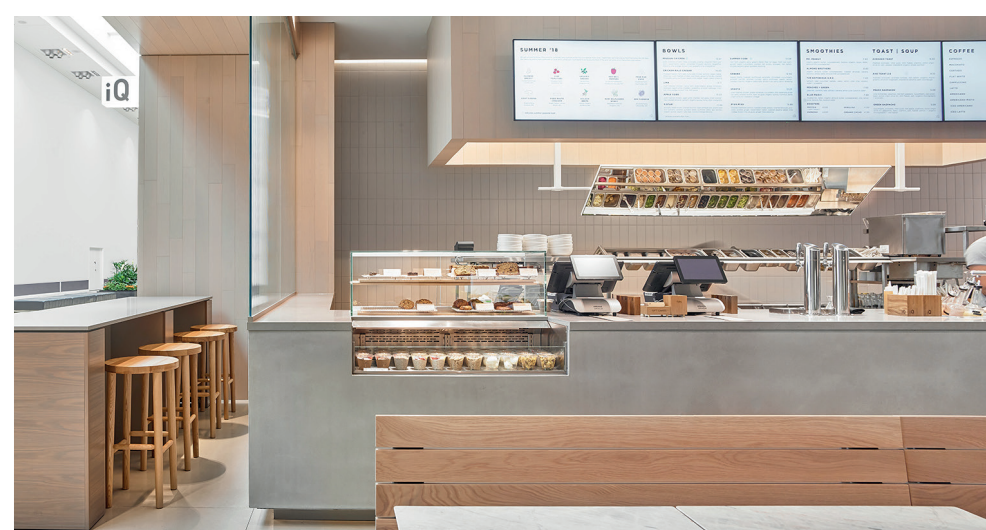

4.5 Closure Grille

A side-folding grille installed by the Landlord at Tenant's expense has the following specifications:

Manufacturer: Dynamic Closures (Ontario) Ltd.

Contacts: Doug Smith

Telephone: 1-905-639-9472 (Burlington) / 1-888-462-2201

Model: SL PERF

Finish: Clear Anodized.

Site Details: The side-folding closure grille shall have top and bottom locking posts. A spring loaded drop-bolt engaging a bottom socket and a top lift-bolt is to protrude into the track and header system.



4.6 Tenant Menu Board Criteria

In order to maintain a pleasant and high quality food service ambiance at the First Canadian Place Marketplace, tenants are encouraged to use well designed, non-commercial menu boards in their stores. Menu board designs must be reviewed and approved by the Landlord before construction.

- Dark background with light text or images is encouraged. Limit sign colors to avoid multi-color appearance and enhance visibility.
- Front lit menu board are strongly encouraged in order to avoid high lighting levels that will take away from the food market ambiance. Remotely lit menu boards are accepted using recessed light. Surface mounted track lighting is not permitted.
- Slim line LED menu board are the only rear illuminated menu board types accepted.
- Integrated LCD screens will be permitted with a limit of 2 per Tenant.
- Handwritten menu boards on blackboards are permitted, providing the writing has a professional appearance.

Not permitted:

- No reflective glass or Plexiglas will be permitted to avoid undue reflections.
- No gratuitous advertising panels or illustrations other than Tenant's logo. No more than an area of 35% illustrations will be permitted on the menu boards.
- No embellished menu frames. Maintain simple sign frames. Images to remain inside menu frames.
- No luminescent handwritten boards.



4.7 Interior Lighting Requirements

A variety of lighting qualities to best suit the variable merchandising uses and physical conditions existing throughout the project are required. The following conditions and criteria are required of all Tenants:

- The Tenant is responsible for all lighting within the entire demised premises.
- Tenants must have well-lit stores emphasizing their visual presentation, displays and architectural features. Appointed accent lighting and varied lighting levels that will create interest is encouraged. Light levels of 25 - 45 foot candle (F.C.) for general merchandise and 125 - 225 F.C. for feature displays are required.
- To retain and protect the visual environment of the area for the benefit of all Tenants, each individual Tenant shall limit the brightness of his lighting fixtures to a minimum level of 25 foot candles at the front counter area. The kitchen area must provide for 75 foot candles. All will be subject to Landlord's approval.
- Tenant shall provide incandescent or LED illumination within the front service area. The use of LED lighting technology is preferred for energy saving environmental reasons. The kitchen lighting must be hidden from view.
- All light fixtures shall be of high quality commercial grade and CSA approved.
- All light fixtures and installations must conform to all applicable building and construction codes and regulations.
- The Tenant should provide a baffle where required in order to eliminate direct glare.
- It is strongly encouraged to illuminate food display wherever possible.

- All Tenants must illuminate their front counters by a concealed fluorescent warm white tube installed beneath their tray slide.
- All electrical equipment including transformers, conduits and/or BX cables and all fastening devices must be concealed from view wherever possible. If not possible, the Project Manager must be advised in order to evaluate and resolve aesthetic appearance of the installation.
- Recessed or decorative luminaires are acceptable.

Not permitted:

- No lamps or bulbs will be permitted that are directed or aimed into the mall.
- No mercury vapour or high pressure sodium lamps, strobe, spinner, chase, or moving type lighting will be permitted.
- Suspended or surface mounted track lighting systems will not be permitted.
- No lighting shall be installed in the Landlord's storefront bulkhead or outside the demised premises other than those installed by the Landlord.
- Exposed fluorescent, standard fluorescent, exposed or unshielded neon light fixtures will not be permitted in the sales area and may only be used in non-public, backstore areas.

4.8 Store Interior Design Criteria

- All Tenants are required to provide a high quality, stylistically current, finely detailed and unique interior environment. Interior finishes for flooring, walls, ceiling, lighting, furnishings and décor are to be longlasting and of superior commercial quality.
- All trade fixtures shall be new and of durable quality and finish consistent with anticipated heavy-duty public use.
- All transitions between floor finishes of unequal thickness are to be accomplished by a gradual transition with floor leveling compound to create a smooth and level walking surface.
- Ceiling materials shall be gypsum board, wood or other type of quality architectural material. All ceiling construction including drywall bulkheads and ceilings, are to be properly supported and braced to the building structure.
- The Tenant must submit full details indicating finish treatment at expansion joints where they occur within the retail space.
- Tenant must provide access panels where required to service Landlord and tenant mechanical, electrical and plumbing systems. For tenant's electrical and mechanical services, coordinate with base building mechanical and electrical personnel.

Not permitted:

- Tripping hazards like trim strips and noticeable reducer strips are not permitted.
- Vinyl tile, other sheet flooring goods, and simulated materials such as simulated wood planks are not permitted in the sales area.
- Acoustical tile ceilings and open ceilings are not permitted.
- Tenants shall avoid use of low quality metal gondola type fixtures within the leased area.

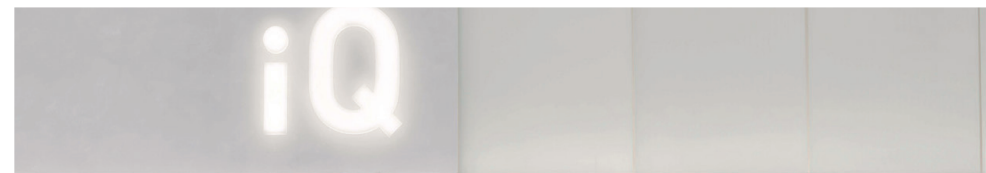

4.9 Primary Signage

In order to promote retail individuality along the Marketplace promenade, Tenants are encouraged to provide interesting and unique storefront signs to their units. All Tenants must have one primary storefront sign for the purpose of store identification only. This sign must be limited to the trade name (as agreed to in the lease documentation with the Landlord) and logo.

Approval of the design of the Tenant's primary signage will be based in part, on the following precepts:

- Signs must be located within the designated Signage Zone, and must not exceed 75% of the total allowed signage bulkhead length and within the Signage Zone. 3D lettering and icon heights within the Signage Zone are subject to Landlord's approval.
- Signs are to be non-illuminated.
- Exposed brackets or fastenings must be painted out to minimize their appearance. Manufacturers' or government labels must be concealed from view.
- Capital letters must not exceed 16" and lower-case 12". The Landlord reserves the right to refuse signage depending on tenant's choice of font or letter style.
- Tenant shall provide a hidden internal sign support to receive 3D lettering and or icons to the top surface of the Landlord provided signage bulkhead as illustrated. No signage company brands or plaques shall be visible to the public area.
- The sign must be pin mounted on the Landlord's bulkhead within the indicated signage zone, as per base building drawings.

Not permitted:

- Signs attached or suspended from the ceiling or the back of the signage bulkhead.
- Flashing, blinking, animated or audible signs.
- Exposed or surface mounted box or cabinet type signs.
- Exposed neon tube or open face channel letters with exposed neon tube.
- Paper, cardboard, cloth, foam or other signs that are not professional in appearance.
- Illuminated signs.

4.10 Secondary Signage

Illuminated or non-illuminated graphic panels or boxes, if located within the Landlord Control Zone, may be permitted as secondary signage, subject to Landlord's approval.

Types of secondary signage within the Control Zone may be:

- Trade name and logos in cut-out metal, wood letters or mosaic inserts within the designated zone on wall or column.
- Channel letters with subtle illuminated sides.
- The secondary signage must be subtle, and should not compete with the primary signage. It cannot cover more than .38 sq. m (4 sq. ft.) in total area.
- Secondary signage will be accepted on the side walls in the Control Zone. Advertising material will not be accepted.

Not permitted:

- Overly lit signage.
- Signs which are not professional in appearance.
- Illuminated sign box or cabinet types signs.
- Promotional poster and other similar stickers or decals.

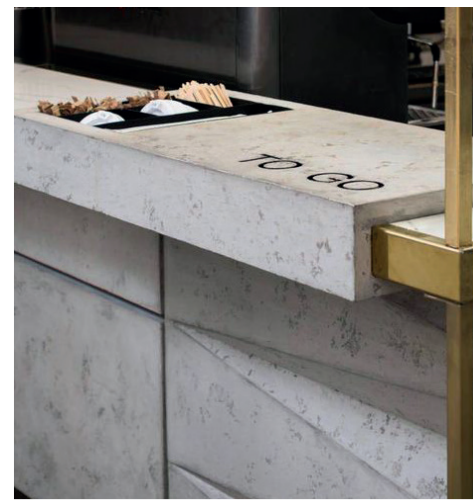

5. Marketplace Design Details



5.1 Typical Condition A

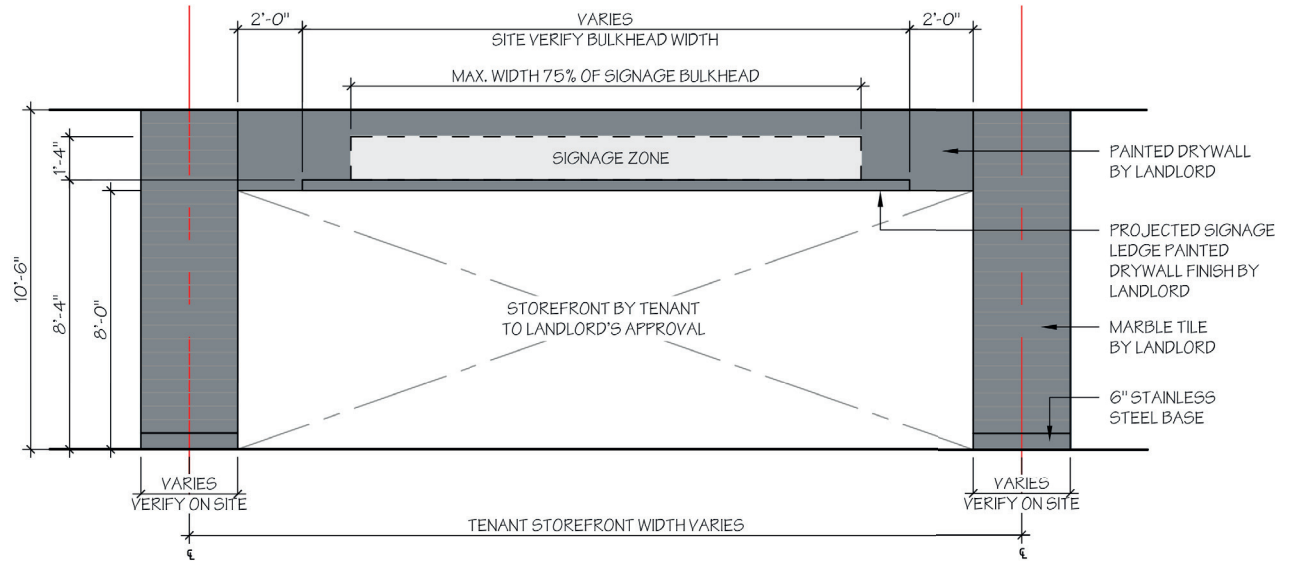

ELEVATION - TYPICAL CONDITION A

Note: Plans for design intent only. Refer to Architect's LOD drawings for more accurate architectural conditions.

- Legend
- by Landlord
 - by Tenant as per Landlord specifications
 - by Tenant
 - Lease Line

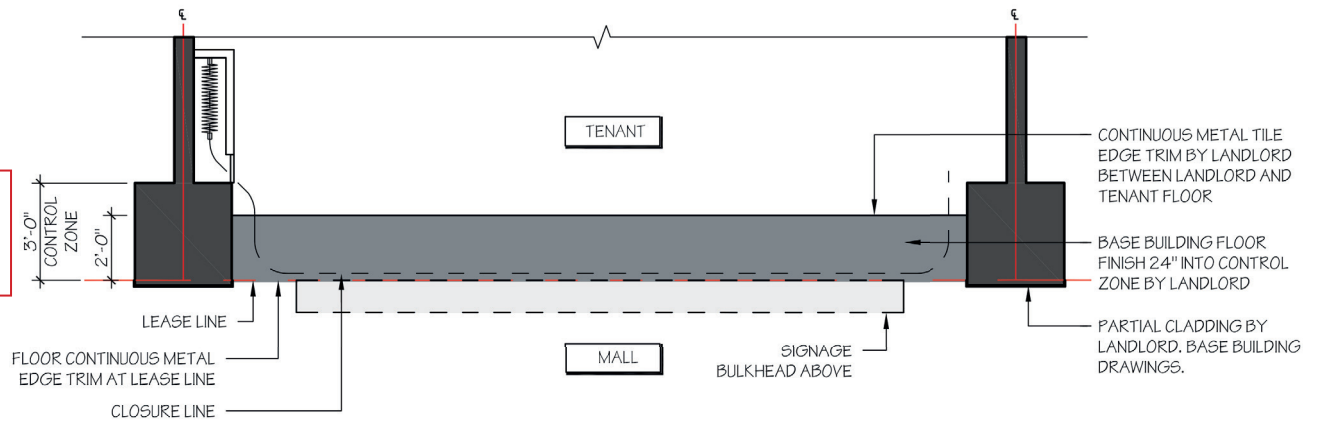

PLAN - TYPICAL CONDITION A

5.2 Typical Condition B

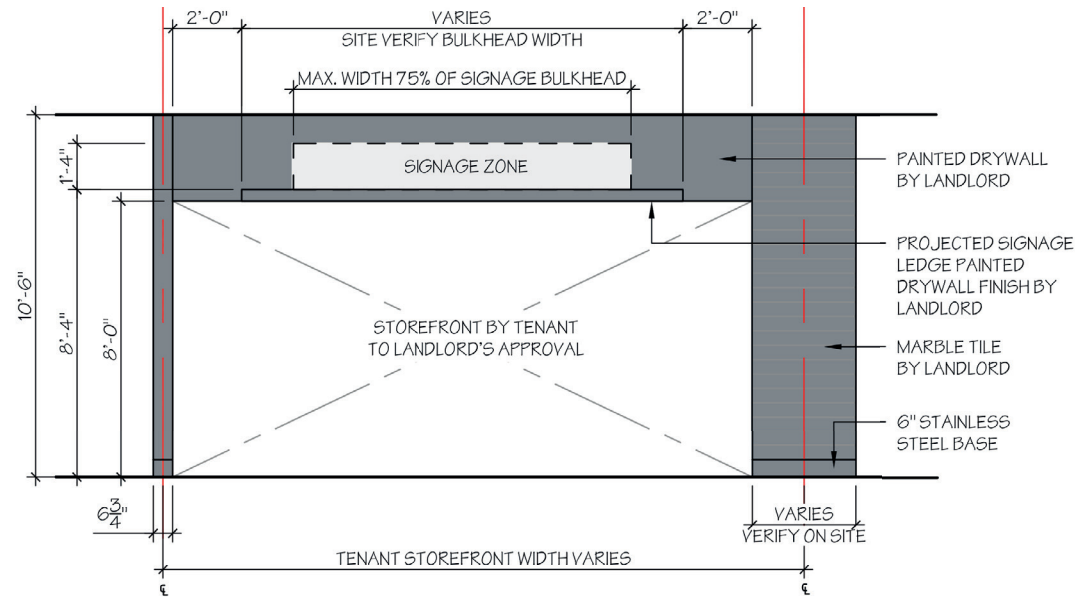

ELEVATION - TYPICAL CONDITION B

Note: Plans for design intent only. Refer to Architect's LOD drawings for more accurate architectural conditions.

Legend

- by Landlord
- by Tenant as per Landlord specifications
- by Tenant
- Lease Line

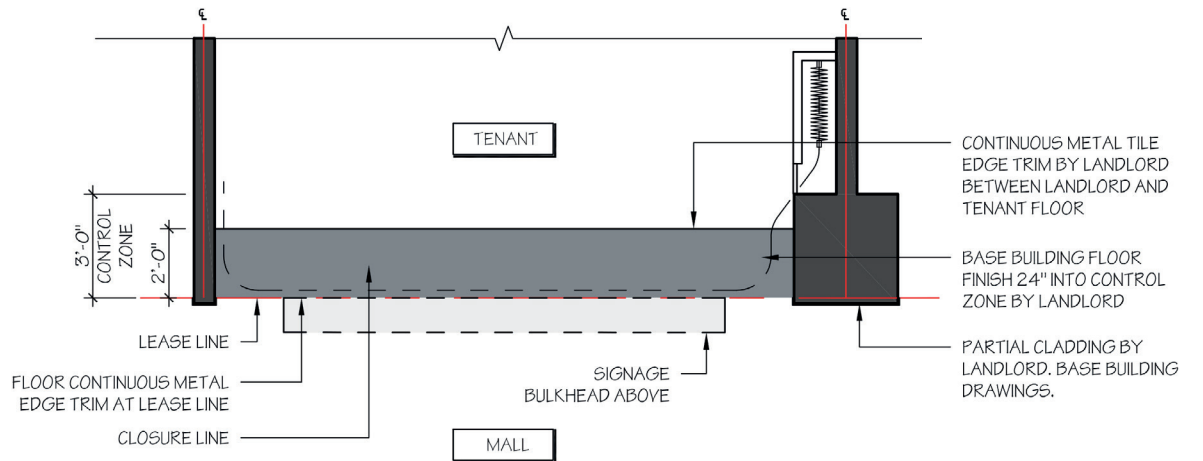

PLAN - TYPICAL CONDITION B

5.3 Typical Sections

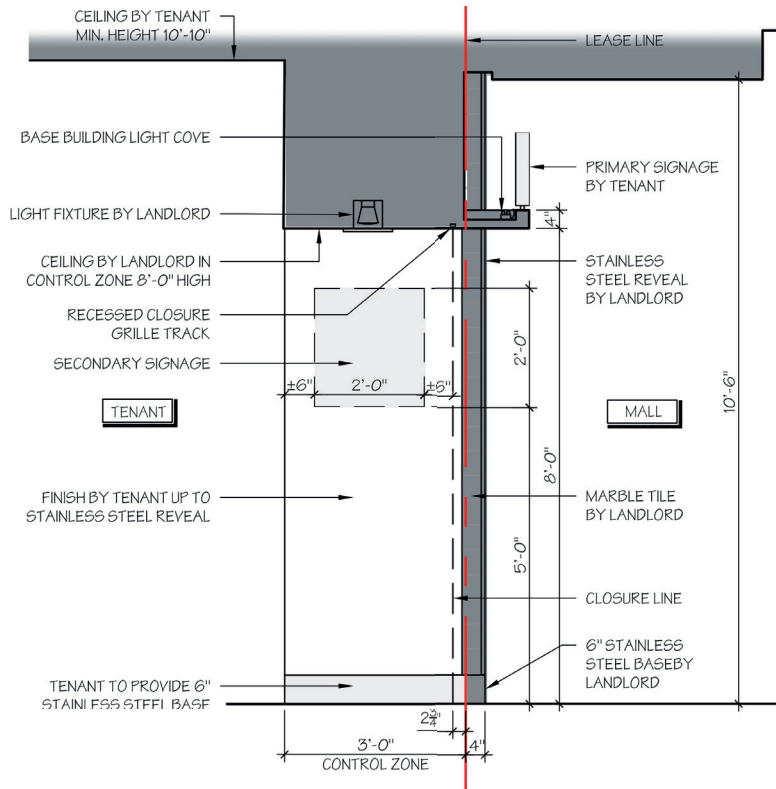

TYPICAL SECTION AT COLUMN

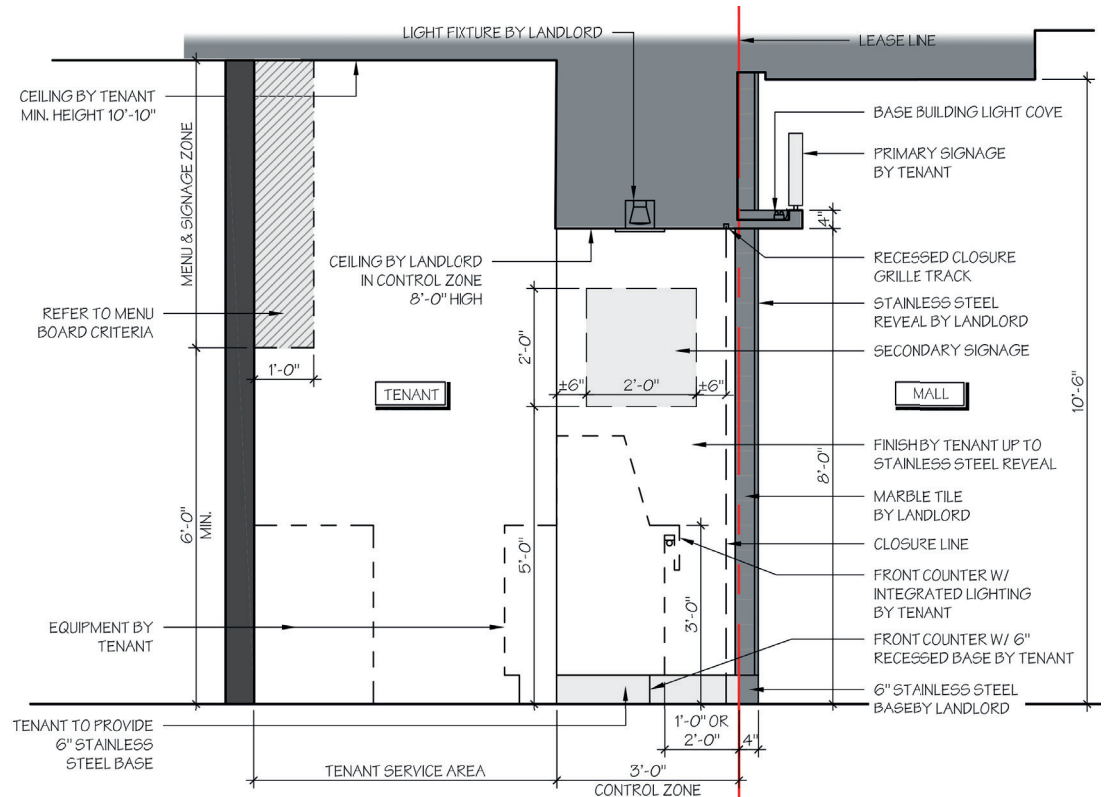

TYPICAL SECTION AT FOOD COUNTER

Legend

- by Landlord
- by Tenant as per Landlord specifications
- by Tenant
- Lease Line

Note: Plans for design intent only. Refer to Architect's LOD drawings for more accurate architectural conditions.

5.4 Variable Demising Conditions

The retail tenant's spaces will be divided according to any of the following Landlord's architectural details or features. Tenants may have a combination of any two demising elements and or an attached fire hose cabinet to their leased space.

The L.O.D (Lease Outline Drawing) and the Project Manager will determine the type of demising caps. For all special demising cap conditions, i.e. corner location or others, Tenant must coordinate with Landlord.

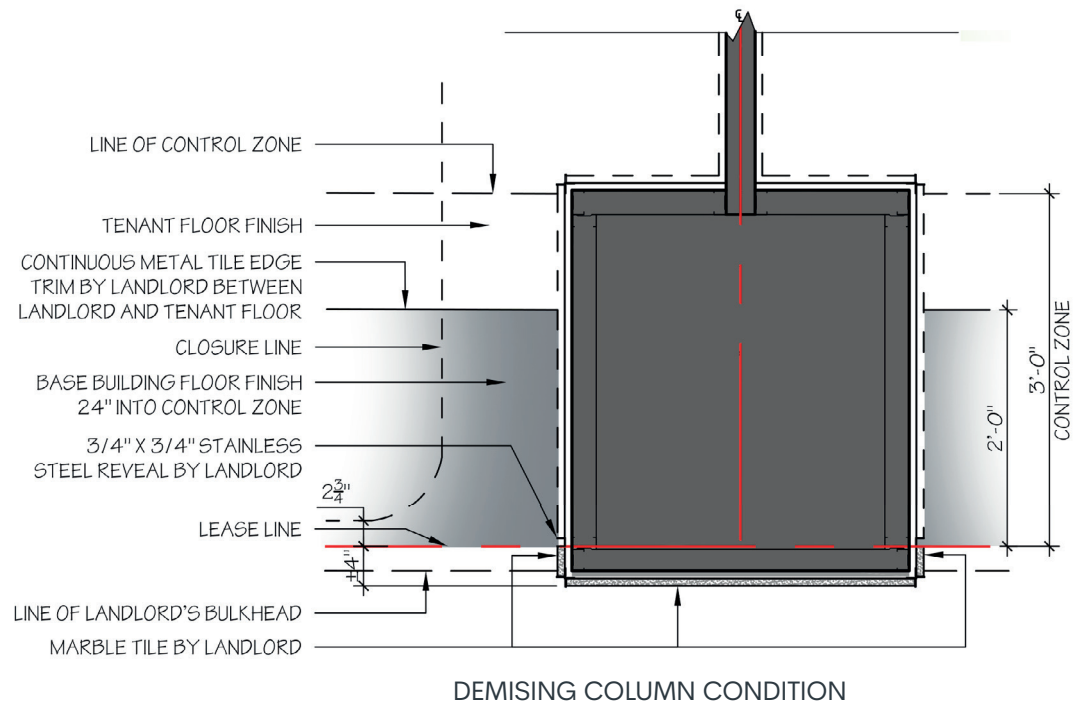

Note: Plans for design intent only. Refer to Architect's LOD drawings for more accurate architectural conditions.

Legend

- by Landlord
- by Tenant as per Landlord specifications
- by Tenant
- Lease Line

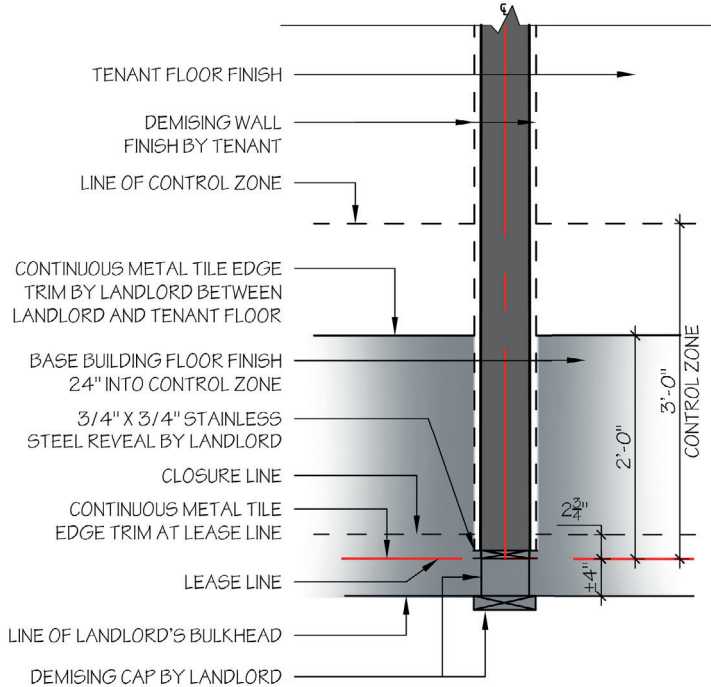

DEMISING CAP CONDITION

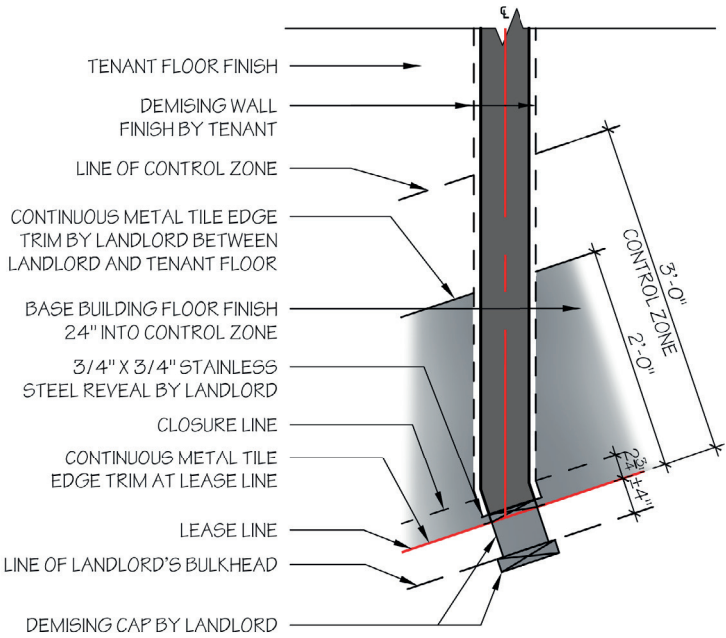

DEMISING CAP CONDITION AT ANGLED LEASE LINE

Note: Plans for design intent only. Refer to Architect's LOD drawings for more accurate architectural conditions.

- Legend
- by Landlord
 - by Tenant as per Landlord specifications
 - by Tenant
 - Lease Line

6. Food Terrace Design Guidelines



6.1 Design Approach

The Food Terrace Design Criteria has been created to allow each Tenant maximum freedom to present their offerings, encouraging strong, quality storefront presentations. The manual is to be followed in conjunction with the Tenant Design and Construction Manual (TDCM) and Schedule "B" attached to the Offer to Lease.

The renewal and revitalization of the Food Terrace is crucial to the successful balance of lifestyle at First Canadian Place; the new design seeks to create an interactive and welcoming core around which the First Canadian Place community can revolve.

This new vision will simultaneously provide an oasis for workers or shoppers and an integrated, intuitive technology hub for informal collaborations and work discussions. New connections can be initiated and old ones nurtured over a delicious cup of coffee.

The Food Terrace is designed to foster the socialization of the working environment and cater to myriad tastes and speeds of consumption. The design concept imagines the floor plane as a system of social spaces of different seating configurations accessed by pathways moving at different speeds.

The ceiling plane is designed to evoke the wide spreading Canadian landscape. An open ceiling of slatted wood brings warmth to the space, offsetting the crisp, pristine lines of the white marble columns. The ceiling flows and meanders with a pliant luxuriousness suggesting slower speeds of movement at its edges, while through its centre, it directs faster traffic with a bolt of light!

6.2 Food Terrace Zones

Food Terrace Units

With 13 eateries, interior seating for 1150 people and exterior seating for an additional 60 people, First Canadian Place's Food Terrace has one of the largest convenience food offerings in the downtown core.

Refer to Section 7.1 for the Food Terrace key plan.

6.3 General Requirements

The following key design directives are to be considered:

- The design should integrate all elements visible by the public, such as the storefront counter, menus, graphics, signage, lighting, equipment and merchandising to create a harmonious whole.
- The design should be original and innovative to enhance food presentations and strongly and attractively brand each unit.
- All storefronts are to be open to the Landlord's common area. No fixed storefronts will be allowed.
- We encourage food demonstrations as long as the equipment is integrated into the overall design.
- Only final preparation areas are to be exposed to the mall, providing the Food Terrace with a unique combination of animation created by the busy employees and food preparation.
- Tenants are to minimize display of equipment exposed to the public, placing them in the kitchen.
- All dimensions are to be verified on site by the Tenant and/or Tenant's designer, general contractor, sub-contractor prior to commencement of any Tenant improvement work.
- Certain base building conditions may occur in some Premises, such as ductshafts with fire-rated enclosures, basebuilding services passing through the Premises, etc. Please note that any relocation of ductwork will be performed by Landlord at Tenant's expense. Tenants are obliged to review their leased premises in detail to determine what localized conditions may pertain and, to determine in conjunction with the Landlord's Project Manager how they may treat or otherwise deal with such conditions.

6.4 Food Terrace Eateries Storefronts

The "storefront" in this project consists of the entire zone starting at the front counter and ending at the wall that separates the concession from its kitchen or preliminary preparation area. The kitchen will be screened/closed off from public view.

Storefronts will be designed, fabricated and installed by the Tenant and are subject to the Landlord's approval. Storefronts must be completely closed by a counter and must consist of a new signage treatment as per the Design Criteria.

Installation of signage and menu boards require prior written approval from the Landlord.

6.5 Counters

- The flooring visible to the public from the common area in front of the counter must be the base building finish. Any touch-ups or adjustments required to be made to the existing base building floor must be communicated to the Landlord and performed by the Landlord at Tenant's expense.
- Tenant is to install a quartz countertop by Ceasarstone, Nougat #6600, polished, 1 1/4" thick with 1/8" chamfered edges. Countertop is to align with the Lease Line and pocket end face.
- Design of the front counter is by Tenant subject to Landlord's approval.
- Counters are to be 3'-0" high. All elements and merchandising must not extend beyond the counter line.
- Height of counter elements and equipment are not to exceed 4'-6". Display cases are to be fully integrated into the overall design by being encased or recessed into the cabinetry. Where refrigeration is not required, the displays should be made up of glass shelves to ensure maximum sight lines. Provide shroud to ensure back of equipment is not visible to public.
- Sneeze guards should be made of butt jointed and electrostatic sealed glass.
- Cash register location is to conform to Landlord preferred location to facilitate efficient queuing. Refer to the Key Plan for preferred locations. Specific deviations are to be coordinated with the Landlord.
- All equipment is to be recessed into the counter and integrated into the design. Provide catalogue sheets of all equipment visible by the public to Landlord along with your design submittal.
- All condiment containers, take out containers, trays, cutlery, POS systems and napkins are to be recessed into the counter at predetermined locations.

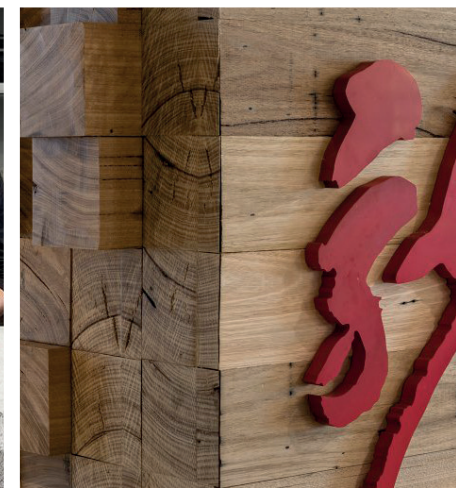
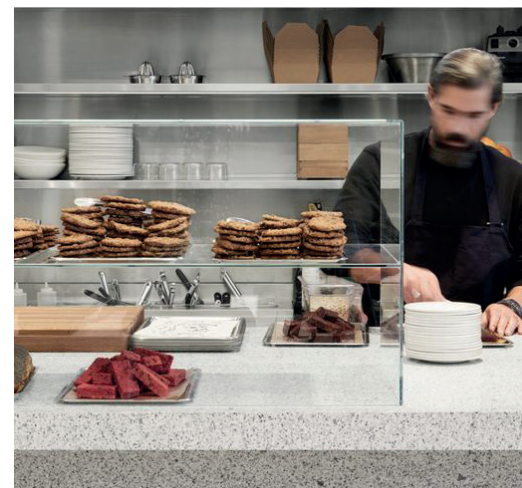
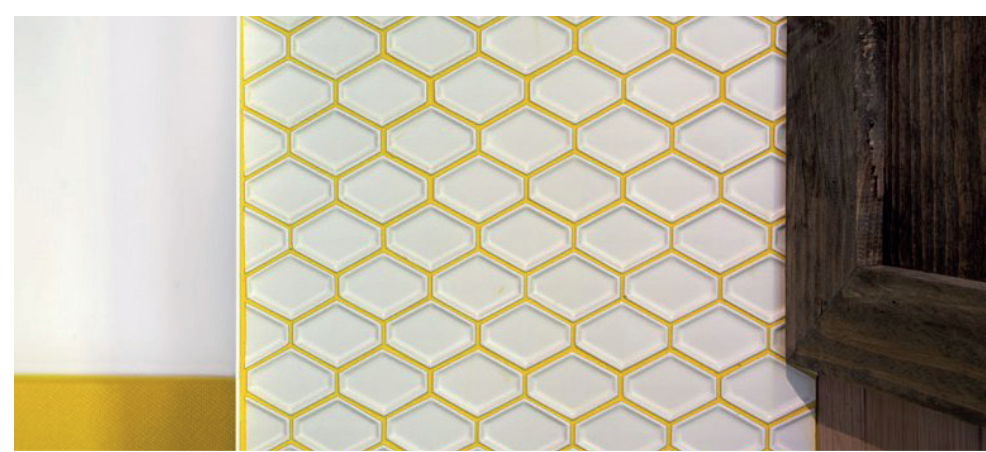

6.6 Closure Systems

- New grille will be supplied and installed by Landlord, at Tenant's expense.

- Closure grille is to be:

Slim Line 4", SL PERF

Finish: Clear anodized Aluminum

Manufacturer: Dynamic Closure

- Landlord will supply necessary pocket enclosures and doors for storage of the closure grille.
- Maintenance of grilles will be by Landlord, at Tenant expense.

6.7 Demising Walls

- Demising walls will be of drywall or concrete block type construction, built by the Landlord, ready to receive Tenant's finishes.
- A demising end cap will be installed by the Landlord.
- Tenants must finish their side of the demising walls, subject to the Landlord's approval, up to the demising end cap tile finish at the storefront (set back 1'- 0" from the Lease Line). Refer to Storefront Typical Sections. For exceptions, refer to Lease Outline drawings.



6.8 Bulkheads and Storefront Signage

In order to promote retail individuality along the Food Terrace, tenants are encouraged to provide interesting and unique storefront signs on their facades. All tenants must have one primary storefront sign per elevation for the purpose of store identification only. This sign must be limited to the trade name, as per the lease agreement with the Landlord.

Tenant's sign will be installed on the standard straight bulkhead, as per the Signage Typical Details in this criteria book. The Tenant's sign design concept is to be submitted with preliminary submissions and is subject to the Landlord's approval. The landlord reserves the right to reject any sign design that is not compatible with the overall criteria.

- All Tenant signs are to be by MCI Millwork Inc. or by Zip Signs. Tenant are to coordinate with MCI, based at 575 Westney Road South, Ajax, Ontario L1S 4N7; Telephone: 905-231-9995. Tenant is to coordinate with Zip Signs, based at 5040 N Service Road, Burlington, Ontario L7L 5H6; Telephone: 905-332-0166.
- The Tenant shall submit shop drawings to the Landlord's Project Manager for review and approval. The sign is a complete product, manufactured and delivered to site for Tenant install on bulkhead face.
- All signs are to be supplied and installed by the Tenant at Tenant's expense as per Landlord's specification. No alternatives will be accepted.
- The Tenant signage must be installed within the zone identified on drawing by the Landlord. The Tenant signage zone will occupy up to a maximum of 50% of the total premises opening width, with a minimum width of 8'-0", and will be centered in the storefront opening. The sign lettering must be maximum 12" high.



6.8 Bulkheads and Storefront Signage (Continued)

- Signs are to have low voltage LED and are to produce a visible brightness/ luminance of 65 to 80 foot-candles. Colour of light will be selected to maximize clarity.
- In the case of a corner unit, the Landlord will consider a second signage shelf. To be reviewed on a case-specific basis.
- All signs shall be constructed, installed and maintained by Tenant at the Tenant's expense, to the Landlord specifications and by Landlord Approved Contractor.
- All permits for signs and their installation shall be obtained by the Tenant or its representative.
- All conduits, transformers or other related equipment must be completely concealed from view from the mall. Exposed brackets or fastenings must be painted out to minimize their appearance.
- Illuminated or non-illuminated graphic panels, if located within the Landlord Control Zone, may be permitted, subject to Landlord approval.
- The sign contractor shall repair all damage to any other work caused by his work.
- Illuminated signs must be controlled by a time clock and are to be illuminated during mall hours.
- The ceiling paint colour for food court tenants must be: Benjamin Moore – F53501 – ULTRA SPEC WHITE

Not permitted:

- No sign-maker's labels or other identification (including UL label) shall be permitted on the exposed surface of signs, except those required by local authorities. If required by local authorities, such labels or other identification shall be in an inconspicuous location.
- No box type backlit signs with translucent background panels are permitted.
- No flashing, blinking, animated or audible signs will be permitted.
- Visible or exposed light sources will not be permitted.
- Advertising or product names cannot be displayed as part of the signage

6.9 Menus and Interior Signs

In order to maintain a pleasant and high quality ambiance of the Food Terrace, Tenants are encouraged to use well designed, noncommercial menu boards in their stores. Menu board designs must be reviewed and approved by the Landlord as part of the design package. Below is a list of guidelines to follow:

- Menu boards and graphics are to be integrated into the overall design and are to be designed by a professional graphic designer.
- Tenants are encouraged to display menus in a non-conventional manner and location and as part of the overall design of the premises.
- All proposed graphics are to be submitted for Landlord's review and approval.
- Dark background with light text or images are encouraged. Limit colours to avoid multi-colour appearance and enhance visibility.
- All wall graphics are to be covered with tempered glass .
- Front lit menu boards are strongly encouraged in order to avoid high lighting levels that will take away from the ambiance.
- Slim line LED menu boards are the only rear illuminated menu board types accepted.
- Integrated LCD screens will be permitted with a limit of 2 per Tenant.
- Remotely lit menu boards are accepted using recessed light.
- Handwritten menu boards on blackboards are permitted, providing the writing has a professional appearance.
- Submit shop drawings showing fabrication and installation for Landlord's approval.

Not permitted:

- Temporary wall signs, banners, sandwich boards, handwritten signs will not be allowed.
- Luminescent handwritten boards are not permitted.
- Surface mounted track lighting is not permitted.
- No reflective glass or Plexiglas will be permitted to avoid reflections.
- No gratuitous advertising panels or illustrations other than the Tenant's logo will be allowed.
- Conventional backlit menu boards are not allowed.

6.10 Ceiling Requirements

- The Tenant ceiling in the Server Area is to be gypsum board with washable quality paint finish.
- Where required, Tenant must provide access panels to facilitate electrical and mechanical servicing. In no case, those access panels should be located facing the Food Terrace space.
- Sprinklers, HVAC systems, linear diffusers and access panels are to be located by the Tenant's mechanical, electrical, and plumbing consultants and to be reviewed and approved by the Landlord.
- Sprinkler heads are to be concealed type and match the ceiling finish.
- Ventilation and air returns must be finished to match adjacent ceiling.

6.11 Interior Lighting Requirements

A variety of lighting qualities to best suit the variable merchandising uses and physical conditions existing throughout the project are required. The following conditions and criteria are required of the Tenants:

- Tenant is responsible for all lighting within the entire demised Premises.
- Tenants are required to use low energy consumption luminaries, of an acceptable decorative standard.
- Tenants must have well illuminated stores emphasizing their visual presentations, displays and architectural features. Appointed accent lighting and varied lighting levels that will create drama and interest are encouraged.
- Varied light levels of 25 to 45 foot candles for general merchandise and 125 to 225 foot candles for feature displays is suggested.
- All light fixtures shall be high quality commercial grade, CSA approved and must conform to all applicable building and construction codes and regulations.
- Recessed or decorative pendant luminaries are acceptable. Decorative pendant lights can be introduced as architectural feature lighting.
- All Tenant lighting in the public area is to be controlled separately and kept on during business hours.
- Tenants are to install automated lighting controls for back of the house areas, i.e. office, washroom, etc.
- All electrical equipment including transformers, conduits and / or BX cables and all fastening devices must be concealed from view.

6.11 Interior Lighting Requirements (Continued)

- All display cases must be lit and vented. Low voltage or LED light fixtures are encouraged.
 - Lighting in coves is to be stagger-mounted for continuous illumination and to prevent hot or dark spots.
 - LED Strip lights will be allowed as recessed accent lighting for cabinets and counters and are not to be visible by the customers.
 - All showcases and display cases must be building code approved and wired to meet all national and local electrical codes. All wiring must be concealed in conduit and located in an area not visible from the mall.
 - Kitchen lighting must be hidden from view.
 - It is strongly encouraged to illuminate food display wherever possible.
 - To retain and protect the visual environment of the area for the benefit of all Tenants, each individual food Tenant shall limit the brightness of his lighting fixtures to a level of 25 foot candles at the front counter area.
 - Lighting used in the servery area must be either LED down lights or pendant lights. The use of LED lighting technology is preferred for energy saving and environmental reasons.
 - Tenants must illuminate their front counters by a concealed LED fixture, mechanically fastened to the underside of the counter.
 - White LED, colour temperature: 3500K, with clear diffuse acrylic lens. Acceptable manufacturers:
 1. GE Lighting - GEWWXNLE1-35K-A Series
 2. Led-Linear - VarioLED Flex Venus-W Series
 3. Cooper - RSA LEDEON Series
 4. Tivoli - Tivoflex Plus Tube Series
 5. Magic Lite - MLS-WW-1-24 Series
- Not permitted:
- Suspended or surface mounted track lighting systems will not be permitted.
 - No typical office grade fixtures are to be used.
 - No lamps or bulbs will be permitted that are directed or aimed to the mall. The Tenant should provide a baffle where required in order to eliminate direct glare.
 - No lighting shall be installed in the Landlord's storefront bulkhead or outside the demised Premises other than those installed by the Landlord, except the front lit signage and front lit base counter finish.
 - Mercury vapour or high pressure sodium lamps, strobe, spinner, chase, or moving type lighting will not be permitted.
 - Exposed fluorescent, standard fluorescent, compact fluorescent or unshielded neon light fixtures will not be permitted in the sales area and may only be used in non-public back-store areas.

6.12 Tenant Responsibilities

The Tenant responsibilities shall include:

- All finishes beyond the Lease Line, excluding the floor between the Lease Line and counter line, and as noted on the Typical Storefront Detail Drawings;
- Premises ceiling;
- Countertop and stainless steel base;
- Glazed screen with abstract graphic applique on front of counter
- Graphic applique to be approved by Landlord (see following page examples);
- Front lit signage letters, to be installed into signage shelf plate;
- Relocation/completion of the electrical, HVAC and sprinkler layouts in accordance with the base-building facilities pending the approval of the Landlord's consultants.
- All fixtures and equipment required for the Tenant's operation.
- Back of house walls and floors are to comply with sanitary local health and sanitary regulations.
- Tenants must install a grease interceptor and/or "hair" basket where required by code, or as determined by the Landlord's engineer. Any upgrades required by the City of Toronto will be at the Tenant's expense.

6.13 Brand Experience

Tenants are asked to create a unique and memorable Brand Experience for the customers, that begins with their product and ends in a consistent integration with the overall design of the Food Court.

A complete holistic design is promoted with the following must-have elements:

- An amazing store concept
- Specifically chosen finishes and colours
- Unique product, display and packaging
- Memorable brand name and logo
- Powerful graphics and strong visual identity
- Impeccable service

6.14 Tenant Identity and Food Display

- Staff must maintain an impeccable presentation of themselves and their unit. Presentation must be organized and neat at all times.
- Displays must be clean and well organized at all times.
- Excessive amounts of items should not be displayed; Storage boxes, trash cans, etc. should be hidden.
- Food display must stay within the Tenant's premises.
- Seasonal visual merchandising changes are encouraged.
- Tenants are subject to routine inspections by Landlord Operations.
- Tenants can integrate exhibition cooking and food display as a way to express the quality and freshness of their product.

Not permitted:

- Visible overstocking and clutter (no boxes, piles of unsorted merchandise, etc.)
- Freestanding promotional items set out on counters.
- Tenants are not permitted to display seasonal decor without the Landlord's written approval. This includes, but is not limited to: holiday string lights, countertop seasonal accessories, fake snow, and seasonal decorative graphics.



7. Food Terrace Design Details



7.1 Key Plan and Preferred Queue

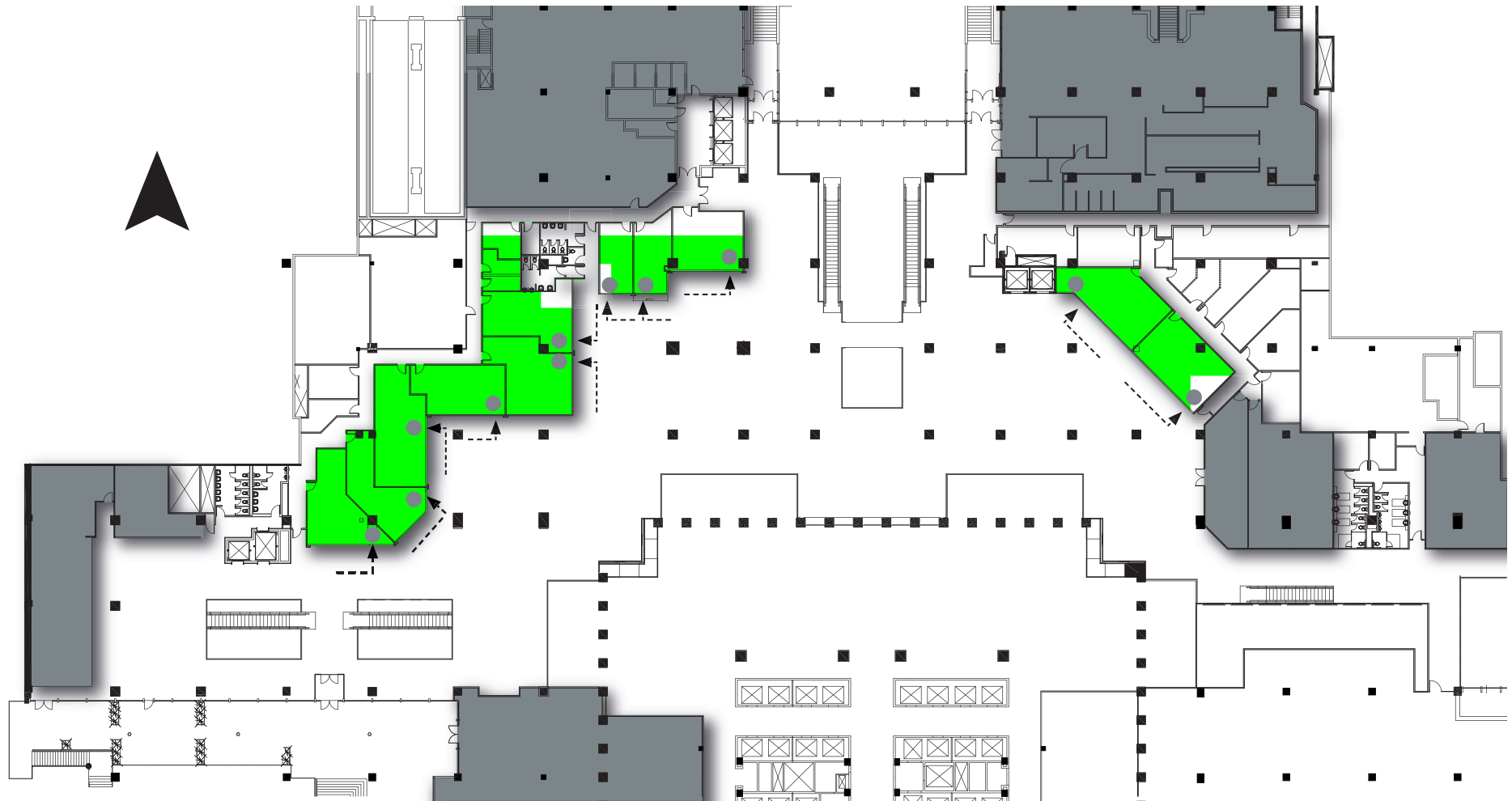

Legend

- Retail Zone
- Full Service Restaurant
- Food Terrace Eateries

- Cash location ●
- Direction of Queue - - - - ->

7.2 Storefront Typical Elevation

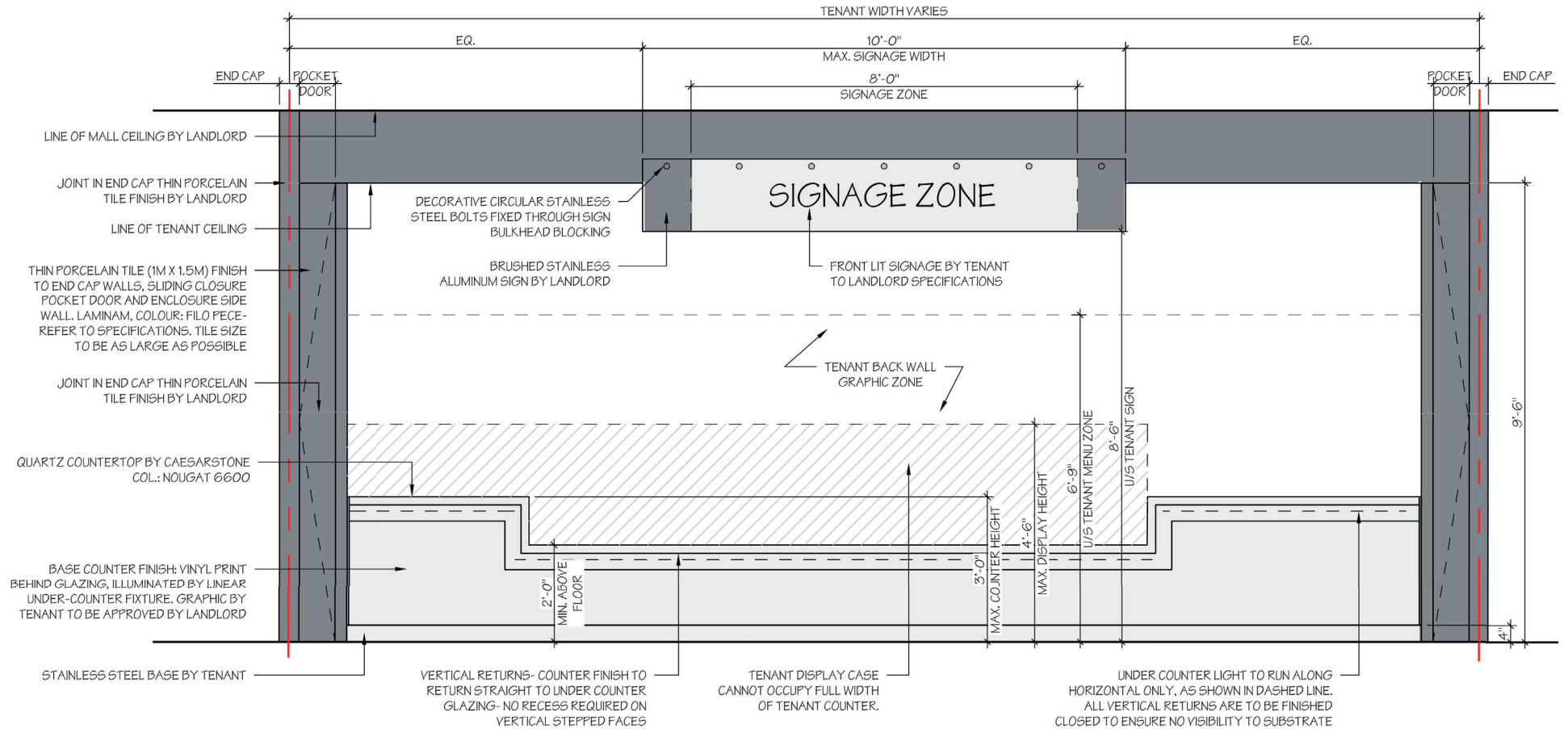

TYPICAL ELEVATION - FOOD TERRACE STOREFRONT

Legend

- by Landlord
- by Tenant as per Landlord specifications
- by Tenant
- Lease Line

Note: Plans for design intent only. Refer to Architect's LOD drawings for more accurate architectural conditions.

7.3 Storefront Typical Plan

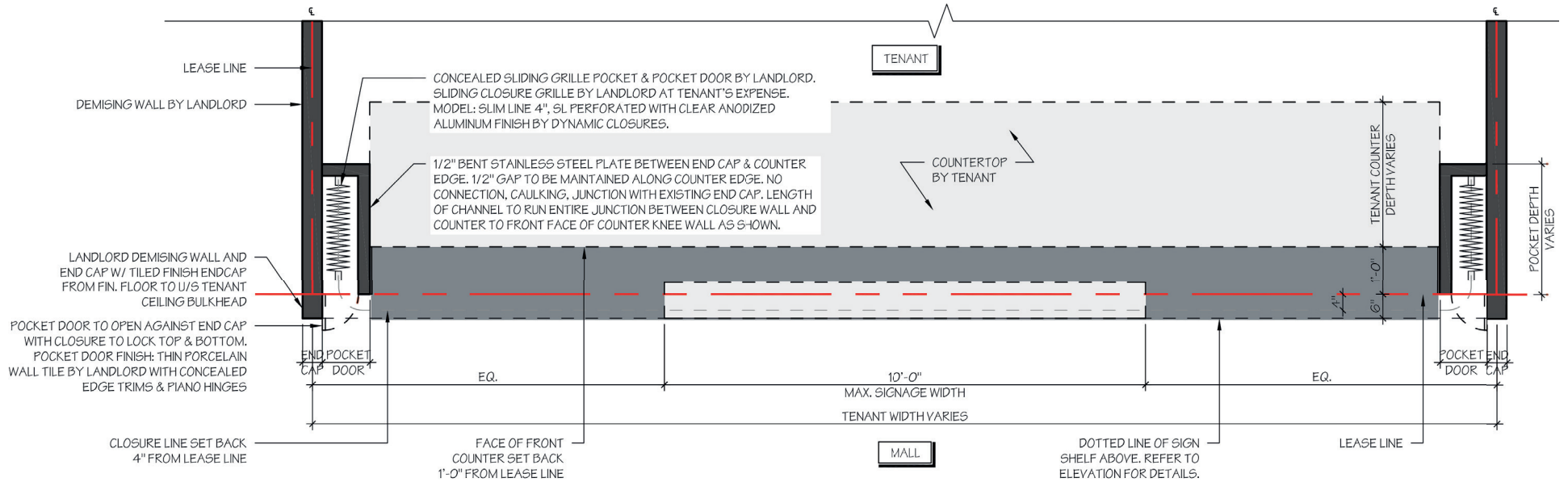

TYPICAL PLAN - FOOD TERRACE STOREFRONT

Note: Plans for design intent only. Refer to Architect's LOD drawings for more accurate architectural conditions.

- Legend
- by Landlord
 - by Tenant as per Landlord specifications
 - by Tenant
 - Lease Line

7.4 Storefront Typical Section

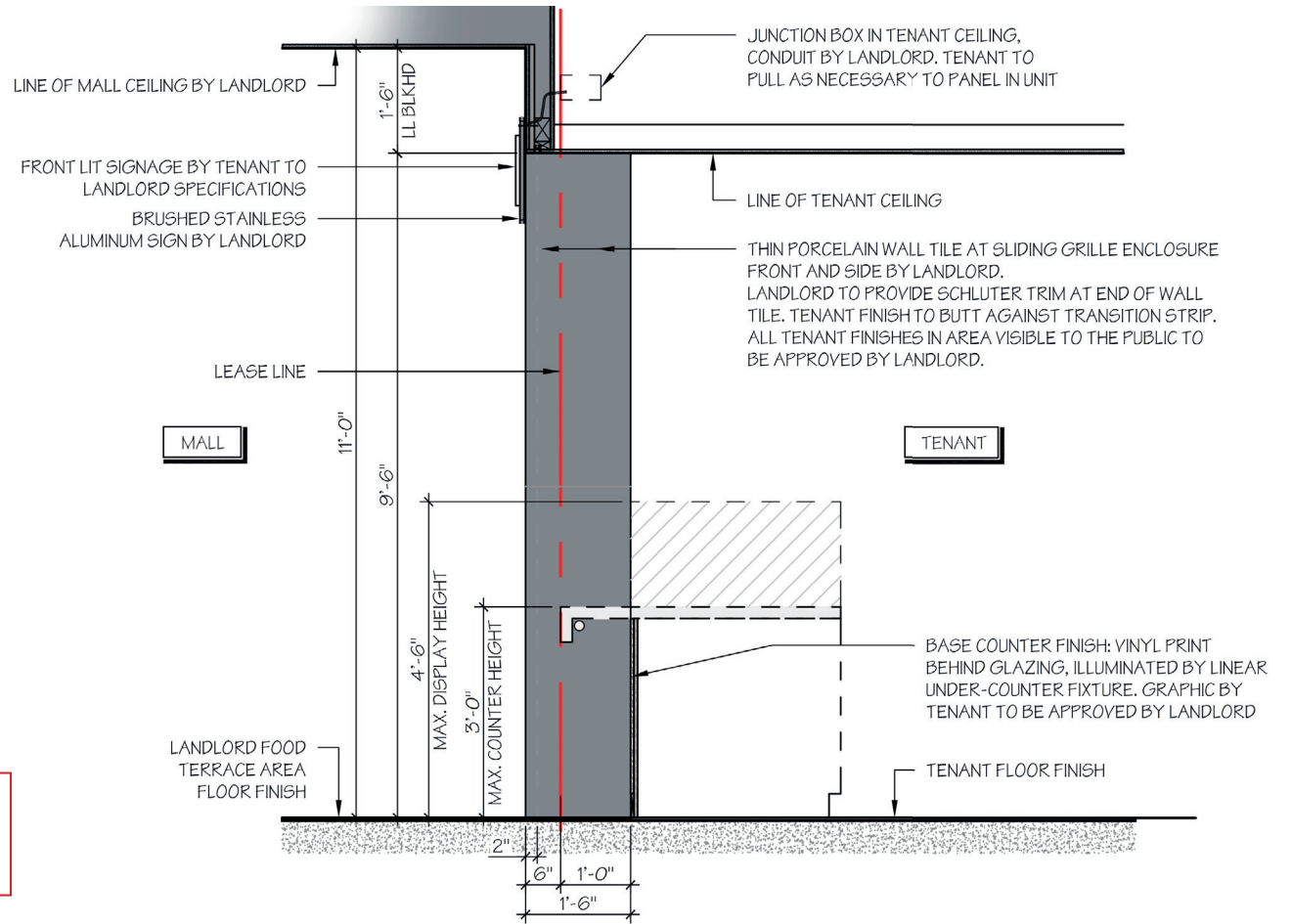

TYPICAL SECTION - FOOD TERRACE STOREFRONT

Note: Plans for design intent only. Refer to Architect's LOD drawings for more accurate architectural conditions.

- Legend
- by Landlord
 - by Tenant as per Landlord specifications
 - by Tenant
 - Lease Line

7.5 Storefront Details

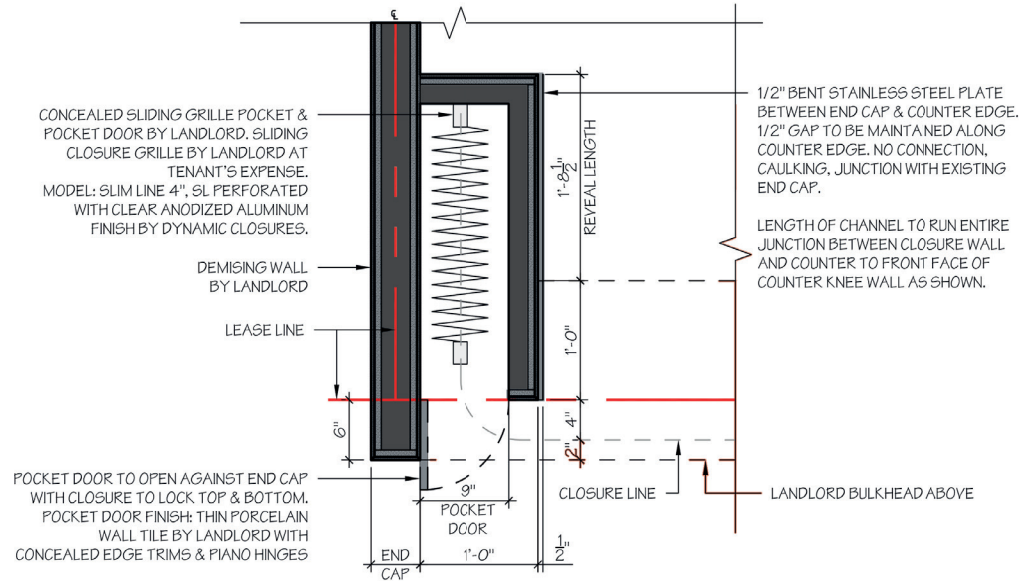

FOOD TERRACE TYPICAL POCKET GRILLE ENCLOSURE

Note: Plans for design intent only. Refer to Architect's LOD drawings for more accurate architectural conditions.

Legend

- by Landlord
- by Tenant as per Landlord specifications
- by Tenant
- Lease Line

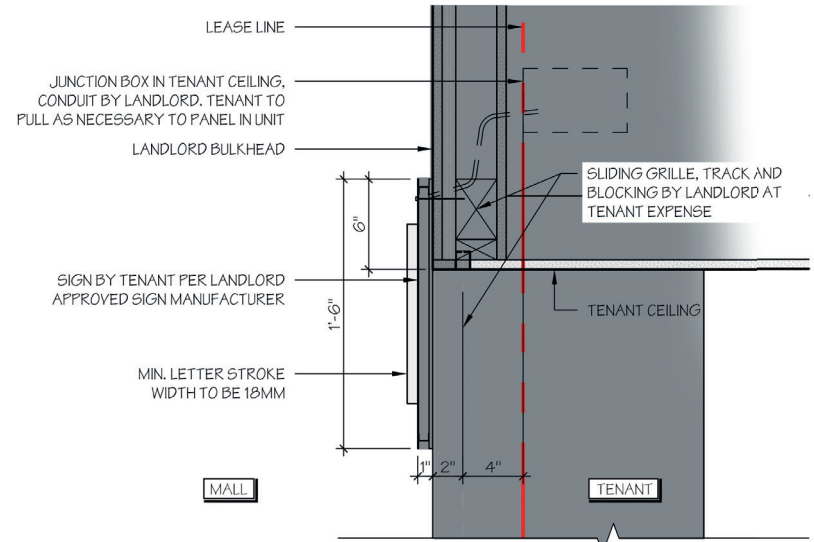

FOOD TERRACE TYPICAL SIGNAGE DETAIL

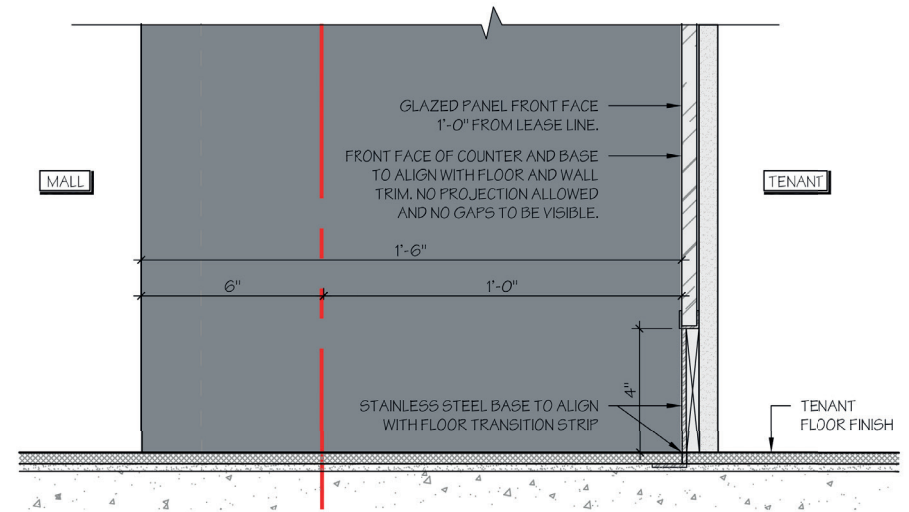

FOOD TERRACE TYPICAL COUNTER BASE DETAIL

8. Mechanical and Electrical Requirements



8.1 Landlord's Work

The Landlord shall perform only the following work on a "once-only" basis and in accordance with its own plans and specifications and choice of materials: for "first-time" tenants in new units:

1. Basic Space:

A basic space, substantially as shown on the plan attached to the Agreement to Lease.

2. Walls:

The Landlord's demising walls consist of exposed concrete block or 152mm (6") metal studs at 400 mm (16") on the centre from slab to slab, clad on the each side with 2 layers of 16 mm (5/8") drywall (taped and sanded) to the underside of the structural slab. Any cutting and patching of the wall for the installation of wiring, plumbing and other fixtures shall be the Tenant's responsibility. Other walls and columns will be unfinished concrete or concrete block.

3. Floors:

Unfinished concrete floor as existing with a minimum of 50mm (2") depression or more, ready to receive Tenant's concrete topping and flooring. Floor loading shall not exceed 100 pounds per square foot.

4. Ceilings:

Unfinished exposed structure. Tenant's consultants should visit the Premises to determine height restrictions. Ceiling loading shall not exceed 10 pounds per square foot.

5. Electrical Services:

a. Power Supply

Access to 120/208V 3 phase 4 wire unfused disconnect switch complete with feeders brought to a location within the CRU, designated by the Landlord, on the basis of a total electrical load of 10 watts per square foot of the Rentable Area of the Premises for

regular Retail Tenants and 40 watts per square foot of the Rentable Area of the Premises to a maximum of 200Amps service for Food Court Tenants as determined by the Tenant's engineer and as confirmed by the Landlord's electrical Consultant.

Digital meters are provided at the Landlord's digital metering panel.

b. Telephone Conduit

A 19mm (3/4") diameter empty conduit for telephone service running from the nearest base building telephone backboard and terminated at a location designated by the Landlord within the CRU is provided.

c. Fire Alarm

A speaker is provided within each Tenant's space as per Code requirements, based on an open area without finished ceiling and partitions. Addition and modification to the base building fire alarm devices and/or systems shall be the responsibility of the Tenant. All final connections and verifications shall be carried out by the Landlord's contractor at Tenant's expense.

Provision of emergency lighting and exit signs shall be the Tenant's responsibility.

d. Natural Gas (for Marketplace and Food Terrace only)

The Landlord will provide a 30mm (1 1/4") natural gas line to the CRU demising wall for the Tenant's connection and a gas meter.

e. Heating, Ventilating and Air Conditioning (HVAC) Access to 25 mm (1") diameter chilled water supply and return lines. Chilled water system is designed to accommodate 6 watts per square foot and 1 person every 75 square feet.

8.1 Landlord's Work (Continued)

f. Kitchen Exhaust and Grease Traps (for Marketplace and Food Terrace only)

A kitchen exhaust system is provided by the Landlord and is terminated at the CRU wall. Exhaust capacity available to Tenants is allotted on an as available / as needed basis. Tenants are responsible for providing ducting within the CRU which shall be NFPA 96 construction, welded steel, and grease tight. The Landlord will maintain at the Tenant's expense, the ecologizer and the central grease trap. Provision and maintenance of CRU local grease traps is the Tenant's responsibility.

6. Mechanical Services (Retail Tenants):

a. Plumbing

The Landlord will provide access only to the following services for Tenant's connection on an as-needed basis; the access locations for these services vary and shall be verified by the Tenants. It may be necessary for the Tenant to core through the concrete floor slabs and walls. Tenant is required to provide fire stopping to reestablish fire separations.

1. 25mm (1") domestic cold water line
2. 40mm (1 ½ ") sanitary vent line
3. 100mm (4") sanitary drain line.

b. Heating, Ventilating and Air Conditioning (HVAC)

25 mm (1") chilled water (supply and return) lines are supplied by the Landlord at each CRU and are terminated at the lease line to accommodate Fan Coil Units provided by the Tenants. The Tenant will be responsible for the provision of any heaters and thermostats including those within the fan coil units. Chilled water system is designed to accommodate 6 watts per square foot and 1 person every 75 square feet.

Treated air is ducted to the lease line at a rate of 0.2 cfm per square foot. The Tenant's CRU design must provide for an equivalent amount of return air to be discharged into the public mall ceiling plenum.

The concourse retail area is within an insulated envelope below grade, and due to an anticipated excess heat load that would require cooling only; there is no provision by the Landlord for heating of individual CRUs.

A Landlord controlled Central Control and Monitoring System (CCMS) for HVAC systems may be implemented at a future date.

7. Fire and Life Safety Services:

a. Sprinkler

A sprinkler system is provided by the Landlord, based on an open floor plan unfinished space and substantially conforming to the Landlord's base building mechanical drawings. Tenants are required to employ the base building sprinkler contractor for any modifications to the sprinkler system at Tenant's expense.

b. Fire and Life Safety

A life safety system including Fire Alarm System is tied to the base building system and sprinkler system in accordance with Base Building Standards. Tenants are required to employ the base building Fire Alarm contractor for any modifications to the Life Safety System, at Tenant's expense.

c. Smoke Evacuation

Smoke evacuation from common public areas is provided in accordance with Base Building Standards.

d. Fire Hose Coverage

Coverage is provided in accordance with Code requirements.

8.1 Landlord's Work (Continued)

8. Tenant's Work to be Performed by Landlord's Approved Contractors

The Tenant's Work set out below shall be performed by the contractors designated by the Landlord (for list refer to page 3 of this Manual) at the expense of the Tenant:

- All approved modifications or connections to the Building Systems, including all work outside the Tenant's Premises, i.e. the base building heating, cooling, ventilation, exhaust, controls, electrical distribution and life safety systems as installed by the Landlord.
- The provision of Additional capacity such as electrical, telephone, air handling, air conditioning, etc.
- Installation of approved modifications to the fire detection and emergency communication system.
- Patching of base building fireproofing.
- Any Tenant Work which could affect the structural component of the Development. Any drilling, cutting, coring and patching for conduit, pipe sleeves, chases, duct equipment or openings in the floors, walls columns or roofs of the Development as reviewed by the structural consultant and approved by the Landlord.
- Installation of any mechanical attachments or other fasteners to the exterior façade (ground floor Tenants only).
- Supply and installation of check meters.

8.2.1 General Requirements

- a. The Tenant shall be responsible for and pay the entire cost of all Leasehold Improvements and all other work in or affecting the Premises. The Tenant is responsible for the preparation of all design and working drawings and specifications relating to completion of the Premises for occupation by the Tenant and the calling of tenders and letting of contracts relating to the Tenant's Work and the supervision and completion of the Tenant's Work.
- b. The Tenant and his agents shall be responsible for verifying all conditions and dimensions on site prior to preparing their drawings
- c. Height limitations are to be checked in Tenant premises under existing Landlord's services.
- d. Access must be provided for all mechanical and electrical devices located above ceilings and behind walls by the Tenant.
- e. Mechanical and electrical consultants should verify that no interference exists with work in spaces below the slab.
- f. All leasehold improvements shall be suspended from the structure independently of base building components such as ducts, pipes, conduits, etc. Provide transition hangers, where required to avoid these components.
- g. Penetrations of structural slabs, walls and beams in excess of 2" in depth must be approved in advance in writing by the base building structural engineer, Entuitive, contact Jamie Hamelin, tel.# 647-401-4516. All penetrations of structural elements of the building shall be x-rayed in advance of coring/cutting. Provide temporary fire stopping, smoke seal and waterproofing of all penetrations in fire rated assemblies immediately following core drilling/cutting if permanent measures will follow at a later date.
- h. All electrical, natural gas and domestic water services must be metered by connection to the Landlord's centralized metering system using the Landlord's approved meters.
- i. If extensive partitioning is used and additional speakers are required within the Tenant's premises, this work shall be done by Landlord's contractor at Tenant's expense.
- j. Interior Finishing: Supply and installation for all other work, interior finishes and installation (beyond those set out in the Landlord's Work), including, without limiting the generality thereof, ceilings, floor covering, extension of base building finishes into the Premises as described in the Landlord's Retail Construction Standards, painting, show window enclosures and display platforms, partitions, special wall and ceiling finishes, vertical and horizontal transportation equipment, trade fixtures and security vaults, and all requirements of licensing, health and other authorities having jurisdiction.
- k. Access panels shall be provided in ceilings where removable tile ceiling systems are not used for access to equipment, including base building elements, which may be located above such ceilings.

8.2.2 Electrical Requirements

Consultant's checklist:

- Location of service termination
- Power voltage and size of service.
- Location of telephone conduit.
- Electrical Load Summary required (Refer to section 5.4)

a. Electrical Installation: Supply and installation of the total electrical installation within the Premises conforming to Applicable Laws and building codes, including but not limited to, panel, breakers in the panel, connection of the panel to the service at a location determined by the Landlord, digital check meters, disconnect switches, transformer, splitter box connection of HVAC equipment, lighting, outlets, emergency and exit lighting and electrical service to signs and water heater. Lighting within the Premises including show windows shall be in conformity with the Landlord's Retail Construction Standards in terms of quantity and quality of luminance.

b. Telephone Service: Supply and installation of all distribution and extensions of telephone conduit within the Premises and all intercom, communication, burglar alarms and signal systems required by the Tenant. The Tenant is responsible for arranging the installation of the telephone service by the phone company.

c. Additional Capacity: If the Tenant requires additional electrical, telephone, air handling, air conditioning or other increased services, it must notify the Landlord. The Landlord will provide the additional capacity, if available. The Tenant will be responsible for any additional costs incurred by the Landlord, including an incremental capital cost for the Building Systems.

8.2.3 Mechanical Requirements

Consultant's checklist:

- Location and size of cold water service
- Location and size of sanitary vent
- Location and size of drain connection(s).
- Grease traps, if required by Tenant under counter or as required.
- Gas Line(s) and Meter, if required, installed by the Landlord's contractor at Tenant's expense. Location and size to be specified.
- Location of kitchen exhaust and CFM required, hood specifications
- General ventilation at night for refrigerator cooling.
- Air velocity across counters and doorways, where applicable in special conditions.
- Heating / cooling load calculations.

Mechanical Installation

- a. **Plumbing:** Supply and installation of all plumbing and piping, equipment, and fixtures required to extend and connect plumbing services from fixtures to the point of connection provided by the Landlord, including provisions for hot water tanks and piping systems that may be required by the Tenant. If water inlet services in excess of those provided by the Building Systems are required, the Tenant may at the discretion of the Landlord be required to provide metering. The provision of public or staff washrooms within the Premises if required by Applicable Laws, including the supply and installation of water closets, wash basins and plumbing and all finishing.
- b. **Heating, Ventilating, and Air Cooling (HVAC):** Supply and installation of all required chilled water fan coil units, duct work, piping insulation, automatic temperature systems, materials, labor, and equipment for the distribution of conditioned air, the removal from the Premises of air not suitable for recirculation and the replacement of such air. The automatic temperature control shall be installed by the Landlord's contractor at the Tenant's expense. For Premises on the concourse level, the Tenant shall provide the required return air connection into the Landlord's mall ceiling plenum along with the required matching ventilation air connection to the Tenant's fan coil unit(s). This shall include all required controls, smoke and/or fire dampers. Supply and installation of any required sanitary exhaust fan and ductwork system. Return Air is to be ducted back into the retail units.

9. Tenant Submission Requirements



9.1 Tenant Information Package

The Tenant Information Package provided to all Retail Tenants shall include the following documents as available:

1. Lease and Lease exhibits: this will define the Tenant's obligations.
2. Lease Plan - will define the Tenant's overall location within the retail centre and dimensions of their space in relationship with the Lease Line. It is to be clearly understood that the Landlord does not in any way guarantee the accuracy of the information contained in such drawings; the Tenant remains responsible for ensuring that the conditions on site and site dimensions are verified and correctly reflected in the Tenant's drawings.
3. Retail Tenant Design Criteria -This booklet together with the revisions to the criteria if applicable.
4. Retail Construction Procedures manual.

9.2 Tenant Design Approval Process

1. In accordance with the Lease, all Tenants are required to supply complete architectural (including separate sample boards), structural (if required), mechanical and electrical working drawings for all leasehold improvements.
2. The Tenant shall employ professional designers and/or architects, electrical and mechanical engineers registered in the Province of Ontario, all subject to Landlord's approval, for the preparation of drawings and specifications. Tenant plan submittal shall bear the seal, BCIN number and signature of the relevant consultant.
3. The Tenant may wish to retain the Base Building's Mechanical and Electrical Engineering Consultants under direct contractual arrangement for the production of working drawings. If the Tenant chooses to employ Consultants other than the Base Building Consultants for its design work, the Landlord may, at his discretion, have such drawings checked by the Base Building Consultants in order to ensure compatibility with the building's systems. The cost of this review will be charged to the Tenant. A list of Base Building Consultants is included in this Manual.
4. The Tenant shall be obligated to provide a copy of this Manual to the appropriate design and construction personnel involved with its premises. The tenant and / or their representative must acknowledge that they have read and have understood the terms of this Manual by signing the form found in this package.
5. After receiving the Tenant Information Package and prior to starting any design or documentation, the Tenant, Tenant's designer and contractor shall make a detailed inspection of the Leased Premises. It is the Tenant's complete responsibility to verify and confirm all dimensions, clearances and existing conditions within the Leased Premises.
6. If there are any deviations from the Design Criteria, the Tenant shall submit a written request for the Landlord's review and approval which shall be at Landlord's sole discretion.
7. Tenants and their architects/interior designers are encouraged to design their storefronts exploring creative uses of merchandising, lighting and signage. The interior of each store should be consistent with the design concept or image created by the storefront. These design goals can be accomplished through close attention to detail, use of high quality materials, good craftsmanship and innovative design.
8. Changes made between Landlord's approved drawings and actual construction will require Landlord's written approval. Such approved alterations shall be made at the Tenant's expense. The approved drawings must be kept at the job site at all times.
9. Tenant construction shall proceed only after Tenant has complied with all requirements set out in the Retail Construction Procedures.
10. All projects must comply with the current construction laws, building codes, rules and regulations of Ontario and standards of construction quality of the First Canadian Place base building construction.
11. Tenants' consultants are to review the relevant sections of the lease for specifics regarding architectural, electrical and mechanical information.

9.3 Preliminary Submission Requirements (Step 1)

The first submission to the Landlord should be made as soon as the Tenant's Architect or Designer has completed preliminary drawings outlining the conceptual ideas for the store.

- The preliminary submission will not be reviewed unless total preliminary package has been submitted.
- The purpose of this phase is to acquaint the Landlord with the Tenant's intentions and to ensure compliance with the Tenant Information Package and base building installations before the final drawing phase.
- Drawings shall not exceed 762 mm x 1067 mm (30" x 42") in size.
- Preliminary drawings shall include 3 sets of prints, stapled into complete sets and two sample boards. These must be submitted to the Landlord's Project Manager as a total package as follows:
 1. Preliminary floor plans (scale 1:50 or ¼"=1'-0"), indicating interior design concept and equipment layout.
 2. Preliminary reflected ceiling plans (scale 1:50 or ¼"=1'-0"), indicating ceiling heights, materials, light fixture types and locations.
 3. Storefront elevations and sections. Locate all major elements and indicate materials and finishes. Submit one storefront elevation in colour (scale 1:50 or ¼"=1'-0" minimum).

4. Details of storefront signs, sections and materials of construction. Indicate letter style and size of graphics including colour and methods of illumination.
5. Interior elevations (scale 1:50 or ¼"=1'-0").
6. Details of proposed menu boards, if applicable.
7. Two complete sample boards, maximum 216 mm x 356 mm (8 ½" x 14"), displaying fully and accurately samples of all finish materials and colours to be used, crossreferenced to the drawings. No plans will be reviewed and approved without a sample board, maximum legal size.
8. Colour photo or colour graphic illustrations of the storefront and interior space.

The Landlord will require 10 business days to review Tenant's preliminary submission.

9.4 Final Submission Requirements (Step 2)

Final review drawings shall incorporate the required changes from Submission 1, be of construction document quality and include 5 sets of the following minimum information (this must be submitted as a total package to the Project Manager). The Landlord will not review partial submissions.

- The Landlord reserves the right to alter any section of Design Criteria information without notice, which may necessitate a further submission by the Tenant.
- These drawings will be reviewed by the Landlord for compatibility with the overall project, comments and/or approval will be marked on one (1) set of drawings or in a letter addressed to the Tenant or its designated representative. Such comments must be distributed to the Tenant's designer/architect and electrical/mechanical consultants.
- All plans, sections and details should clearly indicate the relationship between lease line and demising wall(s) and the design elements. All plans, sections and details should clearly indicate the relationship between the lease line and the storefront.
- Plans shall show building grid lines, scale, designer's name and address, stamp, BCIN Number, date of issue and revision number.
- For the purpose of this Manual, the drawings approved by the Landlord shall be called "Approved Drawings". Any revisions made to the Approved Drawings by the Tenant and/or agents must be clearly marked and submitted to the Landlord for further approval.
- The Landlord will require ten (10) working days to review the Tenant's design submittal. The review will begin upon receipt of the complete design package, including Architectural, Electrical, Mechanical, and if required, Structural drawings as follows:

Architectural

3 sets of drawings and Specifications, 2 samples boards

1. Key Plan showing the location of the demised premises within the project.
2. Demolition Plans (scale 1:50 or 1/4"=1'-0").
3. Final Floor Plans (scale 1:50 or 1/4"=1'-0"). Storefront location and configuration. Locate partitions, fixtures, shelving, racks, counters, signs by dimension and location. Specify all materials, colours and finishes. Indicate any services to be installed that require cutting into the floor slab. Details of mechanical and electrical requirements.
4. Final Fixture Plan (scale 1:50 or 1/4"=1'-0") and final details, including sections, elevations, and finishes for all store fixtures.
5. Final Storefront Elevation and Sections (scale 1:20 or 1/2"=1'-0") showing the storefront relationship with the Lease line and the Landlord's construction elements. Indicate door sizes, construction details, type and direction of opening. Submit a complete storefront elevation in full colour, including signage. Submit shop drawings of glazing, including complete sections and details through storefront bulkhead sufficient for construction, showing the relationship between the Tenant's ceiling and the base building bulkhead and structural support details if suspended from above. Detail sections through floor track assemblies for sliding doors. Indicate the method of connection to ceilings, blocking and framing members. Provide details for all structural supports. Specify all storefront finishes, materials and colours.

9.4 Final Submission Requirements (Continued)

6. Final Details of Storefront Signs (scale 1:10 or 1"=1'-0"), elevation and section views, letter style and size of all graphics form Submission Step I. Detail dimensioned location on bulkhead and lighting requirements; all colours and materials, methods and colours of illumination and wattage requirements, complete mounting details. Proposed signage is to be presented for review on a Manufacturer's Shop Drawing.
7. Final Menu boards indicating all materials and graphics shall be submitted for the Landlord's approval.
8. Two complete Sample Boards - if samples are different from the ones submitted with the preliminary drawings (size not to exceed Legal Size, 216 mm x 356 mm [8 1/2" x 14"]). Colour and material samples must be firmly affixed to the illustration board and labeled complete with fire ratings to suit the City of Toronto code requirements. All samples shall be identified and cross-referenced with the plans as part of the submission package. No plans will be approved without a sample board.
9. Reflected Ceiling/lighting Plan (scale 1:50 or 1/4"=1'-0"), indicating ceiling materials and suspension system, various heights, location of all light fixtures, their manufacturer's name and catalogue cut sheets, lamps to be used and mounting details (recessed, surface, etc). general pattern, grills, diffusers, speakers, sprinkler heads, coves, recesses and access panels. Specify ceiling material by name, thickness and colour, as well as fire rating if required by Code.
10. Interior Elevations (scale 1:50 or 1/4"=1'-0"). Specify wall and fixture finishes. Indicate colours and materials counter referenced with the sample board.
11. Interior Details and Sections, sufficient for construction - (Scale 1:10 or 3"=1'-0") Details showing method of connecting, blocking, framing and mounting of the store fixtures and signs.
12. Interior Finish Schedule

Mechanical

4 sets of drawings (scale 1:50 or 1/4"=1'-0"), Specifications, and digital plans in PDF and AutoCAD most current version with any required XREF, CTB files and font files also included.

All Tenants will be required to retain the services of a mechanical consultant for the preparation of their mechanical plans. All Tenants will be encouraged to employ the services of the Base Building's consultants.

1. Demolition Drawings (scale 1:50 or 1/4"=1'-0").
2. H.V.A.C. Layout (scale 1:50 or 1/4"=1'-0"). Plans and specifications complete with detailed ductwork layout, showing all duct sizes; location of all equipment, dampers, grills, diffusers, thermostats, access doors, other equipment, if required, and air quantities required at each diffuser.
3. Plumbing Layout (scale 1:50 or 1/4"=1'-0"). Plans and specification indicating all equipment, piping runs for drains, vents and water supply, and the location of valves, clean-outs, grease traps and other special or specific requirements. Indicate location of water and gas meters.
4. Sprinkler layout (scale 1:50 or 1/4"=1'-0"). A dimensioned layout of the sprinkler piping and size indicating all sprinkler heads new and relocated.

9.4 Final Submission Requirements (Continued)

Electrical

4 sets of drawings (scale 1:50 or ¼"=1'-0"), Specifications, and digital plans in PDF and AutoCAD most current version with any required XREF, CTB files and font files also included.

All Tenants will be required to retain the services of an electrical consultant for the preparation of their electrical plans. All Tenants will be encouraged to employ the services of the Base Building's consultants.

1. Demolition Drawing (scale 1:50 or ¼"=1'-0")
2. Electrical Plan (scale 1:50 or ¼"=1'-0"). Size and location of transformer (if required), panel location, wiring and circuit diagram. Panel schedule indicating the total connected load, and demand checkmeter (specifications as per "Schedule C" of the Lease Agreement). An electrical equipment and fixtures list indicating wattage of each item (i.e. total connected load, calculated foot-candle values). Wiring schematic diagram showing distribution to all equipment, indicating load generated by this equipment.
3. Reflected Ceiling Plan (scale 1:50 or ¼"=1'-0"). Locate light fixtures, including night, emergency and exit light fixtures. Specify size, wattage, type and mounting. Locate all life safety devices including speakers, pull stations, smoke detectors, heat detectors, and sprinklers.

Structural

3 Sets of drawings and Specifications:

Tenants shall provide Landlord with any additional structural loads imposed on the mall building which includes but is not limited to any floor penetrations, sizes and weights of equipment for Landlord approval. Tenant will be back charged for engineering services that require investigation of loads above and beyond the Tenant's allowable loads.

9.5 Final Review and Approval Process (Step 3)

1. Tenant shall continue to submit unapproved documentation to Landlord until final approval is given.
2. Tenant must submit to the Landlord their contractor's signed copy of "Guidelines for Tenant Improvements" certifying that it has been read and understood by the Tenant and its representatives (consultants, contractor) prior to the commencement of any construction.

9.6 Permit Submissions

1. The Tenant may submit drawings to the local building authority for Permit prior to Landlord approval of drawings. The Tenant shall forward all comments from the building authority to the Landlord for its review. Any change made during Landlord review can be submitted to the local building authority subsequently.
2. Upon receipt of the Building Permit, the Tenant shall forward one (1) set of drawings and copy of the Permit to the Landlord's Project Manager.
3. It is the Tenant's responsibility to advise and have the premises inspected by the Building, Plumbing and HVAC inspectors.
4. Tenant is to ensure the closing of all permits by the City of Toronto and is to obtain the city's inspection status letter confirming that all permits have been closed.

10. Construction Documentation



10.1 Commencement of Tenant Construction

The Tenant is required to engage its own contractors for the purpose of carrying out its leasehold improvement work. The Tenant must carry out all construction work in strict accordance with the Approved Drawings. Likewise, the Tenant's design and construction work must comply with all applicable laws, by-laws, codes and regulations. It is the Tenant's responsibility to ensure that its Contractor(s) observe and comply with all applicable construction safety regulations including, but not limited to O.H.&S. and W.H.M.I.S. requirements.

The Tenant shall engage, at the Tenant's expense, the Landlord's pre-approved contractors, for any mechanical, electrical, sprinkler, fire alarm, controls and balancing modifications or additions to the base building systems.

The Tenant's contractor may be issued revisions to the documents outlining regulations and procedures for the Tenant's contractors and subcontractors on the job site from time to time, as site conditions warrant it.

Construction may proceed only after the Tenant has complied with the following:

- a. The Tenant's Lease for the Premises has been executed.
- b. The Tenant has submitted a "Construction Deposit" based on 3% of the value of construction (minimum \$1,000 and maximum \$10,000)
- c. The Tenant has provided acceptable evidence of insurance as per the Lease.
- d. The Landlord shall issue verbal or written notice to the Tenant advising that all the conditions prerequisite to the commencement of Tenant's Work have been complied with to the satisfaction of the Landlord provided such notice is without

prejudice to any right or remedy available to the Landlord.

Construction may proceed only after the Tenant Contractor has complied with the following:

- a. Provided copy of application, issued building permit(s) and hard copy of permit drawings;
- b. Posted all required permits on site;
- c. Made available at the Leased Premises, a set of prints of the Landlord Approved Drawings and building permit drawings for the duration of the construction period for reference by the Landlord's and City Building Department authorized representatives;
- d. Provided acceptable evidence of insurance for self and all sub-contractors (unless provided by the Tenant) to the Landlord for \$5 million, naming the sub-contractors, Landlord and the Manager as additional insured;
- e. Submitted Notice of Project for the Tenant's Work (for projects over \$50,000)
- f. Submitted a construction schedule;
- g. Submitted valid certificate from Worker's Safety and Insurance Board;
- h. Submitted copies of Addenda;
- i. Provided a list of subcontractors indicating contact names and telephone numbers for after hour emergency use;
- j. Submitted completed Building Access Form from the Building Operations and Security Centre, prior to the commencement of work.

10.2 Procedures During Construction

Contractor is to submit to the Tenant Coordinator during construction:

- a. Copies of all site-meeting minutes.
- b. Copies of all contemplated changes to the Tenant's Work at time of issuance to Tenant's Contractors.
- c. Copies of all site visit reports by the Tenant's Consultants.
- d. Copies of all site reports from authorities having jurisdiction.
- e. Any Tenant Work which could affect the structural component of the Development. Any drilling, cutting, coring and patching for conduit, pipe sleeves, chases, duct equipment or openings in the floors, walls columns or roofs of the Development as reviewed by the structural consultant and approved by the Landlord.
- f. Installation of any mechanical attachments or other fasteners to the exterior façade (ground floor Tenants only).
- g. Supply and installation of check meters.

10.2.1 Tenant's Work

The Tenant's Work set out below shall be performed by the contractors designated by the Landlord (for list refer to page 3 of this Manual) at the expense of the Tenant:

- a. All approved modifications or connections to the Building Systems, including all work outside the Tenant's Premises, i.e. the base building heating, cooling, ventilation, exhaust, controls, electrical distribution and life safety systems as installed by the Landlord.
- b. The provision of additional capacity such as electrical, telephone, air handling, air conditioning, etc.
- c. Installation of approved modifications to the fire detection and emergency communication system.
- d. Patching of base building fireproofing.

10.2.2 Inspection of Tenant Premises

- a. The Landlord and its Agents, Architects, Engineers and Consultants shall have unlimited access to the Tenant's premises for the purpose of inspecting the Tenant Work in progress. The Landlord or its consultants may note deficiencies in the Tenant work, which shall be corrected by the Tenant immediately.
- b. After completion of Tenant work an inspection shall be made between the Landlord's representatives and the Tenant for both Tenant and surrounding areas. Deficiencies noted by Landlord regarding tenant work will be corrected prior to the removal of the hoarding. Any damages caused by the Tenant's Contractor to adjacent areas in the execution of the Tenant work shall be repaired by the Landlord's Contractor at the Tenant's expense.

10.2.3 Hoarding

- a. Tenant construction site must be hoarded and secured to prevent excess noise and dust proliferation. Hoarding will be installed by the Manager at the Tenant's expense.
- b. The hoarding will be positioned maximum 3' beyond the lease line, built of gypsum, full height, taped, sanded and painted, complete with black vinyl base and double doors.
- c. A key to the secured hoarding will be supplied to building security to allow building staff access to the premises at all times for the entire duration of the construction.

10.3 Completion of Tenant Construction

A deficiency inspection will be carried out by the Landlord upon completion of the installations. Please schedule such inspection with Landlord's Project Manager, prior to the removal of the hoarding (by tenant's contractor).

Upon completion of the construction the Tenant/Tenant Contractor will submit the following closing documentation:

Prior to opening for business:

1. Final Engineer's and architects/designers' inspection reports stating that the installations have been completed in accordance with the contract documents and authorities having jurisdiction for occupancy permit purposes. Tenant is to provide a Certificate of Substantial Performance prepared by the primary Consultant.
2. Material and Test certificates for sprinkler and standpipe work, certifying that the installations conform to N.F.P.A 13 (1999) standard and N.F.P.A. 14 standard respectively as applicable.
3. Fire suppression system verification and testing certificate (for food service Tenants)
4. Consultant approved Air Testing and Balancing report.
5. Exhaust hood balancing report (for food service Tenants).
6. Fire Alarm system verification and testing certificate.
7. Final Electrical Safety Authority Certificate of Inspection.
8. Confirmation from the Tenant that all electrical panels have been tagged with lamacoid nameplates and typed circuit directories updated.
9. Verification of all required meter installations.
10. Confirmation that permits have been closed by Authorities Having Jurisdiction. (Building personnel is to attend final inspections, specially for food service Tenants)

10.4 Mechanical Requirements

10.4.1 Smoke Evacuation System

The retail levels of First Canadian Place are protected with a central smoke evacuation system. All Tenants are required to:

- Maintain the location of the existing smoke exhaust ductwork, dampers and smoke exhaust air transfer ducts in demising walls. Do not relocate or remove smoke exhaust ductwork or dampers without the approval of the Landlord.
- Provide direct access to the smoke evacuation duct opening in ceiling from Tenant space (i.e. 24" x 48" in T-bar ceiling, or 30" x 30" in drywall ceiling).

10.4.2 Fire Hose Coverage

- The retail levels of First Canadian Place are protected with a standpipe system equipped with 75 ft fire hoses and fire extinguishers located throughout the mall.
- If additional standpipe services are required, or need to be relocated, this work will be performed by the Landlord's contractor at the Tenant's expense.
- The retail levels of First Canadian Place are protected with a standpipe system equipped with 75 ft fire hoses and fire extinguishers located throughout the mall.
- If additional standpipe services are required, or need to be relocated, this work will be performed by the Landlord's contractor at the Tenant's expense.

Within 60 days of opening for business:

1. Proof of closing of permits. Copy of "Inspection Status Letter" from the Customer Service of the City of Toronto Building Division, indicating that the project has been completed "substantially in accordance with plans issued with the permit(s)" and providing completion dates.
2. General Contractor's valid WSIB Certificate.
3. Complete set of "As Built" drawings, both hard copy and AutoCAD format (DWG extension - most current version, with any required XREF, CTB, and font files) approved by the Tenant's Consultants.
4. An executed Statutory Declaration from the Tenant and the Tenant's Contractor stating that all monies owing to their suppliers and subcontractors have been paid and that no liens have been registered against the Landlord's property.
5. Proof of maintenance agreements for Tenant's equipment.
6. Operations and Maintenance Manuals divisions 1 to 16.

10.4.3 Sprinklers

- The building is fully sprinklered.
- The retail level sprinkler coverage shall be designed as Ordinary Hazard, Group 2, or greater.
- Sprinkler heads shall be standard coverage and response type.
- In drywall ceilings, sprinkler heads shall be concealed type.

10.4.4 Chilled Water Supply

- The building has a central chilled water plant that provides chilled water at approximately 480F during normal business hours.
- The Tenant shall specify cooling equipment based on a minimum chilled water temperature rise of 150F.
- The Landlord will provide valved and capped connections at the demising wall sized to suit an internal heat gain allowance of 30 BTU/square feet.
- The Tenant designer shall specify a balancing valve with the maximum flow demand to be set by the Landlord approved Balancing contractor.
- If the Tenant requires additional cooling or extended hours of operation, these may be provided by the Landlord, if available, as an additional operating cost to the Tenant.

10.4.5 Ventilation

- Outdoor air supply to the retail levels is supplied by the Landlord's central air handling units that provide conditioning to the mall.

- The building has a limited network of sanitary exhaust ducts for Tenant washrooms. If required, and available, sanitary exhaust ductwork services shall be installed by the Landlord's contractor at the Tenant expense.

10.4.6 Controls

- The building has an Energy Control and Monitoring System (ECMS) manufactured by Johnson Controls Inc. This system provides automatic control of all heating, ventilation and air conditioning equipment, and reports any alarms back to the building services center.
- All mechanical equipment shall be specified to operate only during occupied hours and be shut-down during non-occupied hours. The Tenant shall ensure that control valves are closed automatically during unoccupied periods.
- All HVAC controls shall be connected to the building ECMS by the Landlord's approved control contractor at the Tenant expense.

10.4.7 Heating Water Supply

- The building has a waste heat recovery system that can provide Tenants with low temperature heating water at 85°F for domestic hot water pre-heat, de-humidification, zoning control or make up air heating.
- If required, and available, low temperature heating water service connections shall be installed by the Landlord's contractor at the Tenant expense.

10.4.8 Plumbing

- The building has a limited supply of plumbing connections, and therefore, unless specified otherwise in the Lease, the Landlord can not guarantee that domestic cold water, sanitary or vent connections are available within the premises or directly below the premises.
- If required, and available, plumbing service connections shall be installed by the Landlord's contractor at the Tenant expense.
- The Tenant is responsible for installation of water heaters within their premises. Water heaters shall meet minimum energy star ratings.
- Hot water tanks must be installed with a containment pan with a drain hooked up directly to a floor or hub drain.
- Tenant shall be responsible for all internal distribution of supply, waste and venting of new fixtures. All piping to be as follows:
 - a. Sanitary and vent greater than 2" shall be cast iron
 - b. Sanitary and vent 2" and less shall be type "DWV" copper
- Domestic cold, hot and tempered water shall be Type L copper
- Cold, hot and horizontal drain lines shall be insulated with vapour barrier.
- Tenant shall provide an electronic type water meter (as manufactured by Carma) for each main water connection servicing the space .
- Plumbing fixtures shall be low water consumption type, as follows:
 - a. Washroom fixtures shall be commercial grade
 - b. Water closets shall be low consumption type (6.0 LPF) or dual flush system.
 - c. Urinals are to be low consumption type (1.9 LPF)

- d. Lavatory faucets shall be equipped with an energy efficient aerator.
 - e. Kitchen sink faucets shall have a maximum discharge of 8.7 LPM.
- Provide floor drains in all kitchens and washrooms. Install membrane type waterproofing in all kitchens, washrooms.
 - Grease interceptors shall be installed where required by local jurisdictions or determined by the Landlord's engineer.

10.4.9 Additional Requirements for Food Preparation tenants

- Tenants are required to install a grease trap(s) to serve their drains prior to connecting to the building sanitary sewer system.
- Tenants are required to provide their own complete kitchen exhaust and make up air systems. Any cooking appliances that is likely to release grease laden vapours shall be exhausted in accordance with NFPA-96.
- Kitchen exhaust ductwork shall be 16 GA galvanized steel with continuously welded joints.
- If required by the Lease, the Landlord will provide a capped andvalved gas service connection, where available.
- Tenants must ensure that in the event of a fire, the gas service and kitchen make up air systems will be automatically shut down.
- Tenants shall provide supplementary fire extinguishers and kitchen hood protection systems in accordance with Code requirements.
- Tenants are required to provide an odour control unit (ecology unit) before discharging kitchen exhaust to the outdoors.

10.5 Electrical Requirements

10.5.1 Power Service

- The Landlord will provide a service complete with a disconnect based on a calculated load of 8 Watts / square foot, unless otherwise agreed by the Lease.
- The Landlord will provide 120 V/208 V- 3 ph/4 wire - 60 Hz for services up to and including 100 Amps. The Landlord will provide 600 V/3 ph/ 3 wire/ 60 Hz for electric services larger than 100 Amps.
- The Tenant shall provide its own transformation within their premises to suit their equipment power requirements if required.
- The Tenant is responsible for providing power to their mechanical equipment including fan coil units, fans, etc.

10.5.2 Lighting

- The Tenant shall provide entrance lighting to suit the building storefront standard.
- The Tenant shall provide back upbattery powered emergency lighting within their premises to meet Code requirements.
- A lighting control system shall be provided for Tenant spaces in excess of 2,500 square feet to automatically shut off the lights during pre-schedule un-occupied periods.
- Wherever possible, Tenants shall utilize LED lights.
- All storage rooms, washrooms, offices and other enclosed rooms shall be provided with motion sensors for lighting control.

10.5.3 Data and Communications

- The Landlord will provide conduit(s) in accordance with the Lease.
- Tenant shall be responsible for contacting their selected service providers and pulling in data/communication cables to their premises.

10.5.4 Security

- The Tenants are responsible for installing their own security devices and surveillance systems.

10.5.5 Additional Requirements for Food Preparation Tenants

- The Landlord will provide an electrical service complete with a disconnect based on a calculated load of 40 Watts/square foot, unless otherwise noted on the Lease.
- The Landlord's contractor will provide the required fire alarm devices at the Tenant's expense.

10.6 General Requirements

Mechanical and electrical consultants should visit the site before preparing sketches of their layout.

- a. Mechanical and electrical consultants should verify that no interference exists with work in spaces below slab.
- b. Location of holes to be submitted to the Landlord for structural engineer's approval by Tenant at Tenant's expense.
- c. Height limitations to be checked in Tenant premises under existing Landlord's services.
- d. Access openings to all base building equipment in ceiling space shall be installed in the Tenant's ceiling by Tenant.
- e. Size of the electrical service shall be specified by Tenant's designer, otherwise the service will match the indicated load.
- f. Public address speakers are installed on the mall ceiling at about 75 feet on centres.
- g. All electrical, natural gas, and domestic water services must be metered by connection to the Landlord's centralized metering system using the Landlord's approved meters.

If extensive partitioning is used and additional speakers are required within the Tenant's premises, this work shall be done by Landlord's contractor at Tenant's expense.

10.7 Consultant's Checklist

Electrical:

1. Location of service termination.
2. Power voltage and size of service.
3. Location if telephone conduit termination.
4. Electrical Load Summary required (refer to attached form at the end of this booklet)

Mechanical:

1. Location and size of cold water service.
2. Location and size of sanitary vent.
3. Location and size of drain connection(s).
4. Grease traps, if required, by Tenant under counter or as required.
5. Gas Line(s) and Meter, if required, installed by Landlord at Tenant's expense (location and size to be specified).
6. Location of kitchen exhaust and C.F.M. required.
7. General ventilation at night for refrigerator cooling.
8. Air velocity across counters and doorways, where applicable in special conditions.
9. Heating/cooling load calculations required.

11. Required Forms



11.1 Form Requirements

It is be the Tenant's responsibility to ensure that a copy the following forms is provided to their Consultants, General Contractor and Sub-Contractors as applicable and as required. Forms must be completed and returned to the Tenant Coordinator prior to commencement of work.

Tenant and Contractor's Acknowledgement Form

The undersigned or those acting on his behalf have read these rules and regulations governing construction and agree to abide by the same in performance of the work required in the Tenant space.

Accepted and agreed this ____ day of _____

By: _____
Tenant

Accepted and agreed this ____ day of _____

By: _____
Contractor

Retail Tenancy: _____

Name/Title: _____

Address: _____

Telephone: _____

Electrical Load Summary Requirements

Designer to submit this form to the Engineer. The completed form must then be issued for approval to the Tenant Coordinator.

Tenant:		Tenant No.:
Designer:		
Contact:		Telephone:
Store Name:		Sq.ft.
Area Name:		
<u>Electrical Load Summary - Ballast loss must be included:</u>		
Fluorescent Lighting at:	Volts:	Watts:
Incandescent Lighting at:	Volts:	Watts:
Mercury Lighting:	Volts:	Watts:
Electric signs:	Volts:	Watts:
No. of Receptacles	Volts:	Watts:
Hot water heater for washroom at:	Volts:	Watts:
Air conditioning at:	Volts:	Watts:
Special purpose receptacles (specify):		
Watts:		
Watts:		
Watts:		
Watts:		
Watts:		
Watts:		
Note: If space is insufficient, provide additional list with complete data on loads.		
Total connection load at 120/208 volts, 3 phase		Watts:
Total connection load:		Watts:

Brookfield
Properties